

Topological Features in the Emerging Solar Magnetic Flux

Ilan Roth 

Space Sciences Laboratory, University of California, Berkeley, CA 94720
email: ilanr@berkeley.edu

Abstract. The formation of highly structured, spatially localized complex structures during solar flux emergence facilitates adaptation of topological methods, extending the research of emerging macroscopic MHD fluxes into knots, links and braids. Combining mathematical considerations, remote images and *in situ* satellite observations at solar vicinity, we construct new characteristics of those braided/knotted magnetic structures, applying Braid and Knot Theory to physical configurations, deducing their topological invariants, constraining the evolution and stability while delineating the relaxation path to magnetized equilibria.

Keywords. solar corona, magnetic braids, emerging knotted magnetized structures

1. Introduction

The directly observed magnetic solar activity is a product of processes starting deep in the solar convection zone with the ensuing flux emergence into the overlying solar atmosphere. Magnetic flux bundle undergoes a lengthy evolution: (a) dynamo generation and growth, (b) buoyant ascension through a broad range of external thermodynamic parameters and (c) transport through interaction with the surrounding ambient magnetized plasma, resulting in major structural modifications [Cheung \(2014\)](#). Solar observations reveal filamentary nature of the emerging magnetic fields with highly structured three-dimensional magnetic loops in the overlying solar corona. Various simulations indicate that the survival of a coherent flux structure in the presence of the destructive effects of convection may require the progenitor flux tube to form twisted configuration, resulting in several observable features, like sigmoidal field lines [Fan \(2009\)](#). Similar features may result due to photospheric shearing flows along the polarity inversion line [Leka et al. \(1996\)](#). However, small-scale emerging regions close to the photosphere appear as tangled bundles of braided magnetic fields with a writhe or winding [MacTaggart and Prior \(2021\)](#). These indications facilitate implementation of Braid and Knot Theory allowing us, together with remote images and *in situ* satellite observations at solar vicinity to construct topological characteristics of magnetic structures and predict their dynamics as they emerge into solar atmosphere, evolve in the corona before being ejected into the solar wind.

2. Magnetic Braids and Knots

Solar braids were coined as such due to the inferred geometry of the observed solar emissions, indicating adjacent strands passing over or under, consistent with a 2-D projection of a braid [Berger and Asgari-Targhi \(2009\)](#). The braiding of the field lines is due to the ubiquitous small-scale motion at the photospheric leg(s) of the emerging magnetic field and interaction with the magnetized coronal plasma.

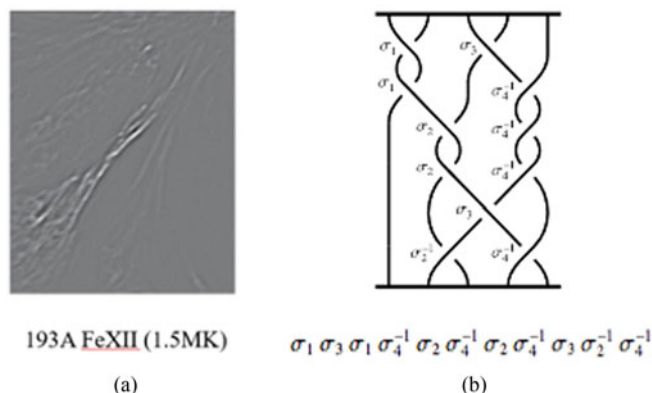

Figure 1. (a) Small-scale magnetic braids observed by Hi-C rocket at 193Å [Cirtain et al. \(2013\)](#). (b) An example of Artin braid with conversion of braid structure into algebraic expression. Notation from top to bottom: the i -th strand passing from above over the $(i - 1)$ -th strand defines the crossing generator σ_i , while passing below it forms σ_i^{-1} .

Following observations of a small section of the coronal field lines [Cirtain et al. \(2013\)](#), magnetic braids may be depicted as a disjoint collection of crossings among a number of strands attached to foot-points at two photospheric planes (“top” and “bottom”), with one-to-one correspondence between the foot-points (Figure 1a) forming a small scale braid-like topology [Thalmann et al. \(2014\)](#), similarly to the Artin braids [Artin \(1947\)](#) - set of n disjoint strings in 3-space attached to two (horizontal) bars at the top and at the bottom (Figure 1b). The observed loops are undergoing moves preserving their topological equivalence as described by Artin braids group operations, which may be represented through algebraic expressions, while new loops light up, fade out or connect into more extended compact structures [Thalmann et al. \(2014\)](#). Braids and knots and their physical analogues at the solar corona form topologically related entities. Mathematical knots and field lines of magnetized plasma in the MHD approximation are described as closed loops or bundles in three-dimensional (3D) space, transformed dynamically via continuous deformation of 3D upon itself, pushed smoothly in the surrounding viscous (plasma) fluid, respectively, without self-intersection. The physical “frozen in” condition for magnetic knots is equivalent to the knot “ambient isotopy” controlled by the three Reidemeister diagrammatic moves (e.g. [Adams \(2004\)](#)), as shown on Figure 2: R_1 - twist (green), R_2 - poke (orange) and R_3 - slide (yellow or blue). R_j moves reduce then the complicated topological problem to a simpler diagrammatic one, relating the changes in the observed projection to the relations between the crossings in the magnetic configuration. The invariance under R_j assures that any quantity which characterizes the magnetic field knot must preserve its value while undergoing the R_j transformations, becoming a topological invariant which assigns uniqueness to each knotted magnetic configuration. Non-equivalent magnetized knots are characterized by explicit helicity/winding invariants in the form of various polynomials (e.g., Alexander, Conway, Jones, Kauffman).

3. Closure of Braids

An important relation between braids and knots/links was given through the Alexander [Alexander \(1928\)](#) theorem, stating that any knot may be obtained from a closure of some braid, joining orderly through simple arcs the endpoints at the upper loose ends of a braid with the lower ones. Conversely, there exist many braids which through closure become the same knot - the mapping is surjection, not injection.

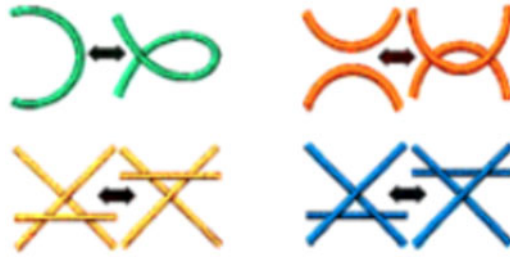

Figure 2. Reidemeister moves: R_j , $j = 1$, green; $j = 2$, pink; $j = 3$, yellow/blue.

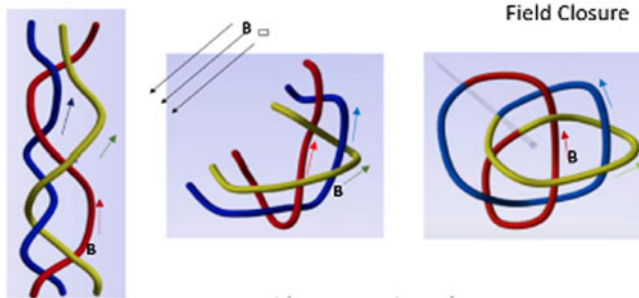

Figure 3. (a) Initial braid state. The arrows indicate the braid field polarity. (b) Skewed braid interacting with reverse polarity fields (black arrows). (c) Morphing of a braid into a knot.

Magnetic braids constitute a perturbed system in marginal equilibrium, which exhibits natural fluctuations due to interaction with the ambient field, resulting in reconfiguration of field elements with emission of excess energy in the form of fluid motion and thermal heating. In the rectilinear, non-braided configuration two oppositely directed magnetic field regions are unstable to tearing mode instability. Particle simulations with an anti-parallel, stretched magnetic field configuration like modified Harris model showed explicitly that in a nonlinear phase of tearing mode growth the fast reconnection forms a narrow x-line current layer together with 2D magnetic islands (e.g. [Che et al. \(2011\)](#)). The dynamic contraction of these islands may result in Fermi-like energization of electrons, which emit then the observed X-rays and gyro-synchrotron radiation in flares [Drake et al. \(2006\)](#). In contrast to Harris model, braided magnetic bundles in 3D may follow a different path due to their considerably sheared fields. Magnetic fields in rectilinear configuration in the presence of opposite polarity fields are reconnecting adjacent fields into closed strings of magnetic islands, while a sheared bundle of braided fields (Figure 3a), deformed into more skewed form (Figure 3b), may connect its successive strands through field closure into a new closed structure (Figure 3c), i.e. magnetic knot. Similarly to mathematical knots, these finite width strands, having topological invariants enhancing their stability, which have not been analyzed yet, become the new building blocks of heliospheric magnetic structures, which may be observed through high resolution radiation.

4. Dynamics of the Coronal Magnetic Braids

When a closure of two different braids results in the same knot, magnetic deformation leading from one braid to another describes reconfigurations preserving the knot invariant. This equivalence allows us to predict several of stable braid eigenmodes, which

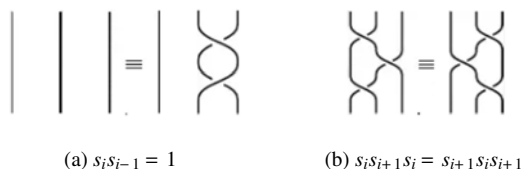

Figure 4. Operators of Artin group.

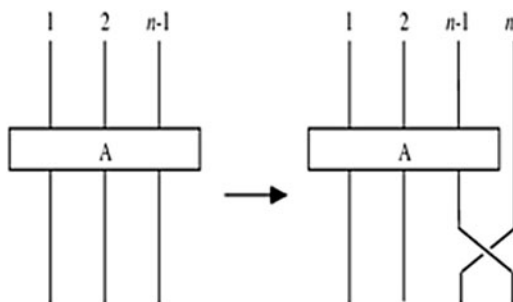

Figure 5. (Second) Markov stabilization (interchange) move.

should be seen in high resolution observations. Denoting the basic braid generators as $s_i = \sigma_i$, the natural candidates include the operations of the Artin group B_n :

(a) $s_i s_{i-1} = 1$. In this move, under local E×B Alfvénic pulse two adjacent magnetic strands interchange positions in parallel to the R_2 knot move (Figure 4a) when they are exposed to different cross forces. The braid preserves its topological characteristics while its word acquires an observable $s_i s_i^{-1}$ modification.

b) $s_i s_{i+1} s_i = s_{i+1} s_i s_{i+1}$. This move describes active magnetic strands anchored at different foot-points while one of them fluctuates with respect to its neighbors, imitating the R_3 knot move (Figure 4b). The braid changes its word to an equivalent one. Both Artin moves, preserving the topological structure of the braid, are predicted as the most prominent fluctuations in high resolution observations.

Another important convergence of multiple (infinite) braids into the same knot is based on Markov theorem [Markov \(1935\)](#), stating that two braids under closure become the same knot if they are related by a sequence of Markov moves. When a single active magnetic field line reconnects with n -th string of a braid A adding a new s_{n+1} crossing string, the resulting knot of $n + 1$ strings formed under closure is isotopic to the closure of A - the new braid converges to the same knot under a closure (Figure 5). The addition of string generator s to A may be repeated many times, forming new braids which do not change the equivalent knot structure. Similar result applies to reconfiguration adding multiple times the generator $(s_{n+1})^{-1}$.

As a corollary of Markov move Theorem, a sequence of these operations which modify significantly the structure of magnetic braid due to coronal heating or emergence of new active field lines, form additional stable modifications of the braid due to closure into identical knot. In contrast, any large braid moves which do not satisfy these conditions are candidates for the configuration destruction.

5. Knot Sum

The fast solar wind is accelerated largely by the local coronal pressure gradients and Poynting vector due to interchange reconnection of new emerging loops at the base of the corona with open magnetic field (e.g. [Fisk \(1996\)](#); [Fisk et al. \(1999\)](#)). Since the braided reconnection events occur at clustered adjacent sites, the magnetic output into the solar

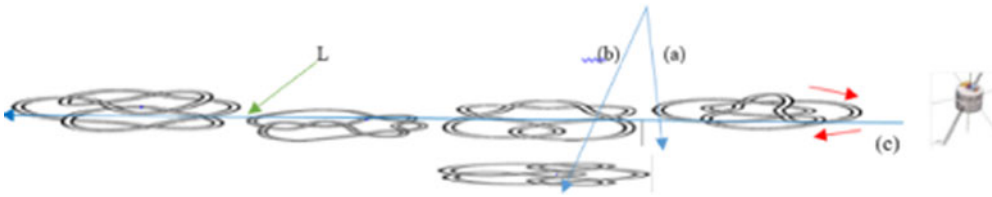

Figure 6. Example of knot sum of different prime knots embedded in the solar wind: red arrows signify the field with reversals; blue lines (a, b, c) describe various encounters.

wind consists of a sequence of propagating knots, analogously to gun discharged bullets or magnetic jetlets. The ultimate structure encountering the inner heliosphere satellites is determined by a topological procedure of mathematical knots: two magnetic knots moving along close trajectories interact when the front of the trailing knot is merging with the tail of the leading knot. This operation - Knot Sum must happen numerous times between two adjacent knots, resulting in formation of elongated composite knots. The resulting switchbacks are the observed magnetic structures ejected into the solar wind (Figure 6).

6. Summary

Application of topological concepts into the flux emerging processes allows us to characterize the structure of solar emerging configurations as braids, which through 3D interaction with an ambient magnetized plasma form robust magnetic knots whose stability is enhanced through their invariants. We then predict the observable eigenmodes of the coronal braids as Artin Group operations and stable coronal heating modifications due to Markov moves. The emerged switchbacks in the solar wind result due to Knot Sum reconnection of the propagating knots. Similar procedure may operate in various astrophysical features, like Herbig–Haro objects in the protostar outflows.

Acknowledgment

The research was carried under NASA contract NNN06AA01C.

References

- Adams, C. C. 2004, *The knot book*.
- Alexander, J. W. 1928, *Transactions of the American Mathematical Society*, 30(2), 275–306.
- Artin, E. 1947, Theory of braids. *Ann. of Math*, 4, 101–126.
- Berger, M. A. & Asgari–Targhi, M. 2009, *The Astrophysical Journal*, 705(1), 347.
- Che, H., Drake, J. F., & Swisdak, M. 2011, *Nature*, 474(7350), 184–187.
- Cheung, M. C. M. & Isobe, H. 2014, *Flux emergence (theory)*. *Living Rev. Sol. Phys.*, 11, 3.
- Cirtain, J. W., Golub, L., Winebarger, A., De Pontieu, B., Kobayashi, K., Moore, R., Walsh, R. W., Korreck, K., Weber, M., McCauley, P., *et al.* 2013, *Nature*, 493(7433), 501–503.
- Drake, J. F., Swisdak, M., Che, H., & Shay, M. 2006, *Nature*, 443(7111), 553–556.
- Fan, Y. 2009, *Magnetic fields in the solar convection zone*. *Living Rev. Sol. Phys.*, 6, 4.
- Fisk, L. A. 1996, *Journal of Geophysical Research: Space Physics*, 101(A7), 15547–15553.
- Fisk, L. A., Schwadron, N., & Zurbuchen, T. 1999, *Journal of Geophysical Research: Space Physics*, 104(A9), 19765–19772.
- Leka, K., Canfield, R., McClymont, A., & van Driel–Gesztelyi, L. 1996, *The Astrophysical Journal*, 462, 547.
- MacTaggart, D. & Prior, C. In *Journal of Physics: Conference Series* 2021, volume 1730, 012013.
- Markov, A. A. 1935, *Recueil Math. Moscou.*, 1, 73–78.
- Thalmann, J. K., Tiwari, S. K., & Wiegmann, T. 2014, *The Astrophysical Journal*, 780(1), 102.