

Macro Techniques and Digital Microscopy

Luther M. Gammon, Boeing, Materials & Processes Technology
P.O. Box 3707, M.C. 73-44, Seattle, Washington 98124

Macrophotography is the merging of photo studio and optical microscopy techniques. This combined technique has all the challenges and methods of both. There is a tendency to overlook the macro aspect of the analysis and go straight to the cross-sectioning or electron microscopic portions of the analysis. All forms of microscopy are complementary to each other. Photo studio and macro imaging work are at the heart of any research project or investigation. This can be the most challenging and difficult aspect of any microscopic project. Once the specimen is dissected, it is often impossible to go back and capture the “as-received” image. As the specimen is broken down or dissected, it can be very difficult to reassemble it to document the section locations.

In any microscopy work there is no substitute for a full understanding of lighting. There are many considerations, such as:

- *The color temperature of the light source-* When using film, the color temperature can be compensated by using color filters. With the digital image this task is usually accomplished with the white balance setting (in the software) on a white background. All types of light sources have unique color temperatures and spectral wavelengths. If a light source is altered using the rheostat setting (controller on the light source) the percentage will impact the color temperature. In general as the percentage of energy is lowered the light bands will be move toward the IR (red) side of the spectrum.
- *Documenting a shiny machined or mirrored surface, i.e. a round bearing (a large challenge) -* Several parameters need to be considered and controlled. If a shiny metal surface such as a ball bearing is placed directly on any background the sides will be mirrored. This will make it very difficult to resolve the edges. Position the part as far from the background as possible, set an open aperture on the lens (<F8) and remove the background from the focal length, i.e. “go to infinity”. The open aperture will defocus the reflections produced. Use a white or light colored background removed from the focal plane. This will allow the edges of a bearing to be resolved.
- *Documenting a fracture face-* This technique is a careful balance between contrast and detail. If circumferential lighting is used, detail will be present but no contrast. If a single low oblique light is used contrast with no detail will be produced. Manipulation of lighting can be balanced for the best view of a fracture face. This can be done using diffusers and multiple lights at multiple focal distances.
- *Photographing a window with cracks-* Reflected light does not work very well for translucent (transparent) materials. By using transmitted light, the cracks are easily contrasted. There are several subtle ways to contrast the cracks.
- *Capture of brightfield macro-image (1 to 25 X) on polished metallographic cross-section (a large challenge)-* On a microscope only the light filament needs to be

aligned, as the rest of the optics are preset. On the macroscope every aspect needs to be customized. Like Kohler alignment on a microscope, the macro alignment of the light source, filament aperture, distance, intensity, halfmirror, and the specimen will need to be hand tuned. It is difficult to produce an instrument that will give a high quality macroimage preset. With the right components and careful alignment a high quality image can be obtained.

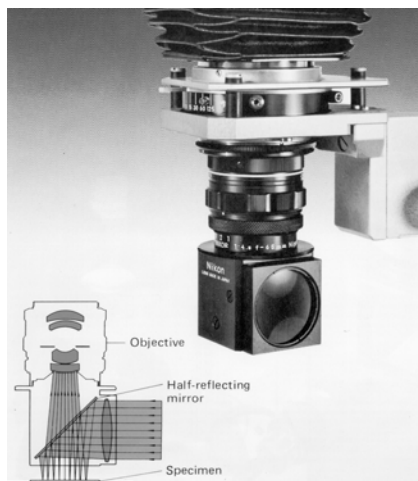

Figure 1 The half mirror is mounted on the end of the 65mm objective on a macro bellows camera

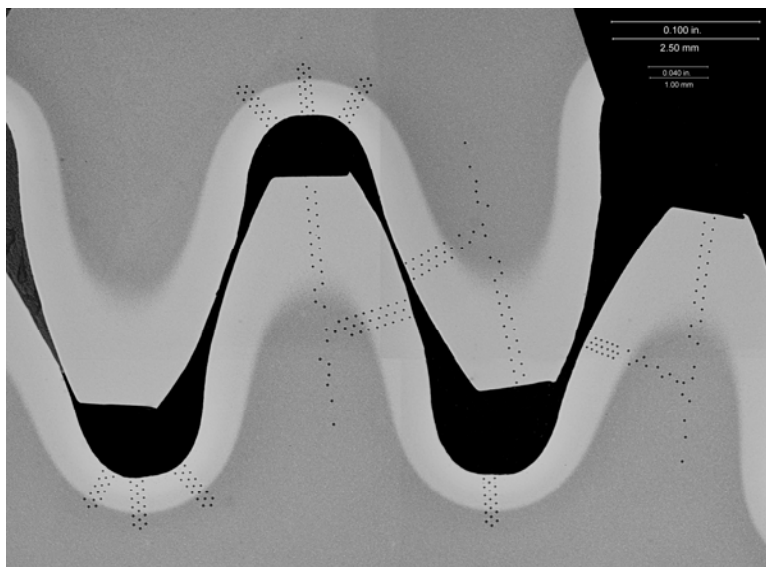

Figure 2 Carburized gear captured with the 65mm lens and half mirror