

INVESTIGATIONS ON STERILISATION BY STEAM.
A NEW PRINCIPLE FOR THE STERILISATION BY
VAPORABLE DISINFECTANTS.

BY SVEND CLEMMESSEN.

(*From the University Institute of Hygiene, Copenhagen (Director: Prof. L. S. Fridericia) and the Copenhagen District Hospital in Gentofte (Surgeon-in-Chief: A. Helsted, M.D.)*)

(With 5 Figures.)

CONTENTS.

	PAGE
Introduction	282
I. Experimental methods	283
II. Experiments	288
III. Results of experiments	291
IV. Discovery of the new principle	295
V. Experiments with formalin	298
Summary	299
References	300

INTRODUCTION.

THE principle of sterilisation by means of steam has hitherto been to place porous or partially permeable articles in a steriliser in an atmosphere of active vapours and to allow these to penetrate into the articles little by little by:

- (1) hygroscopic condensation and absorption (Rubner, 1898);
- (2) condensation (Sambuc, 1885; Budde, 1889);
- (3) difference in specific gravity between air and steam (Walz and Windschied, 1886).

For the sake of accelerating, the following factors have been employed with more or less effect:

- (1) Preliminary heating by a steam jacket.
- (2) Pressure in the oven (Pasteur cited by Hueppe, 1885; Nägeli, 1877; Globig, 1888) and "decompressions" (Washington Lyon).
- (3) Partial sucking out of the air contents of the pores before the steam is let in (America¹).
- (4) Current steam (Koch, Gaffky and Löffler, 1881) through the oven but circulating round the objects (Gruber, 1888).

Sterilising vapours or gases have not hitherto been forced directly through the objects. If this is done, as the experiments cited here show, the penetration through and the heating of the objects—when they are porous—can be effected, practically speaking, in the time it takes to fill the steriliser.

¹ Eine schwimmende Desinfektionsanstalt im Hafen von New York, *Gesundheitsingenieur* (1898), No. 2, p. 29.

The problem of filling the pores of the objects with sterilising vapour, is thereby solved in a rapid and effective manner—an active method in contrast with the previously passive one.

The method depends on the fact that the objects themselves, in containers or free, cover all or most of the outlets—or cover the supply of the sterilising vapours in such a way, that these are either directly forced or sucked through the articles to be sterilised.

It is recognised that there are great differences in the capabilities of sterilisers, and that every new apparatus must be thoroughly tested to make sure that the articles used in operations are absolutely sterilised. Also that an old steriliser must be tested at intervals, as a matter of course.

During the testing of some new sterilisers at the Copenhagen District Hospital in Gentofte, my interest in the subject of sterilisation was aroused, as I could not quite decide the importance or otherwise of using current steam in the type of sterilisers in question. This led to my making a series of experiments which have now extended over two years. One of the sterilisers was fitted up as an experimental apparatus and was systematically tested, varying one condition at a time. Later, I proceeded to compare its sterilising capacity with that of other sterilisers of the same construction, but of other sizes. During these experiments, I found it possible to devise a new construction for steam sterilisers, and the new principle may also, in all probability, be used for the formalin disinfection of porous objects, as it renders possible the rapid permeation of hygroscopic and porous matter with steam or gases.

What follows is a technical description of the experiment, with a brief summary of the series of tests, with the experimental steriliser and the conclusions derived from these tests; next it is explained how the principle of the new construction was found, and how the tests were made to prove its applicability to steam sterilisers. Finally, some orientating formalin experiments are recorded.

I. EXPERIMENTAL METHODS.

The experimental steam steriliser.

The experimental steriliser employed (Fig. 1) was an upright cylindrical one¹ provided with a steam jacket and connectable to a steam plant giving a pressure of two atmospheres (134° C.)². A throttle valve (*R*) was fitted on the main supply pipe so that the steriliser could also be tested when using steam at a pressure of 0·5 atm. (110°).

The sterilising chamber (*S*) was 760 mm. in height, 400 mm. in diameter, and had a capacity of 95·5 litres. The steam supply pipe to the top of the chamber had an inner diameter of 13 mm., and the discharge pipe below had a diameter of 19 mm. The cock (4) on this pipe, called the bottom cock, could be regulated in three positions, viz. “closed,” “quite open,” or “half open.”

¹ Manufactured by W. E. Jensen and Son, Copenhagen.

² All temperatures are given in Centigrade.

The last position allowed a sufficient current of steam to pass through the chamber. If the empty steriliser—the bucket being removed—was filled with saturated steam at 134°, the “half open” of the bottom cock was such that the excess pressure, in the course of 45 seconds, fell from 2 atm. to 0 (*i.e.* to 1 atm. absolute pressure) when the supply of steam to the chamber was suddenly cut off. When in future, “current steam” is mentioned, it means that the bottom cock stands at “half open.”

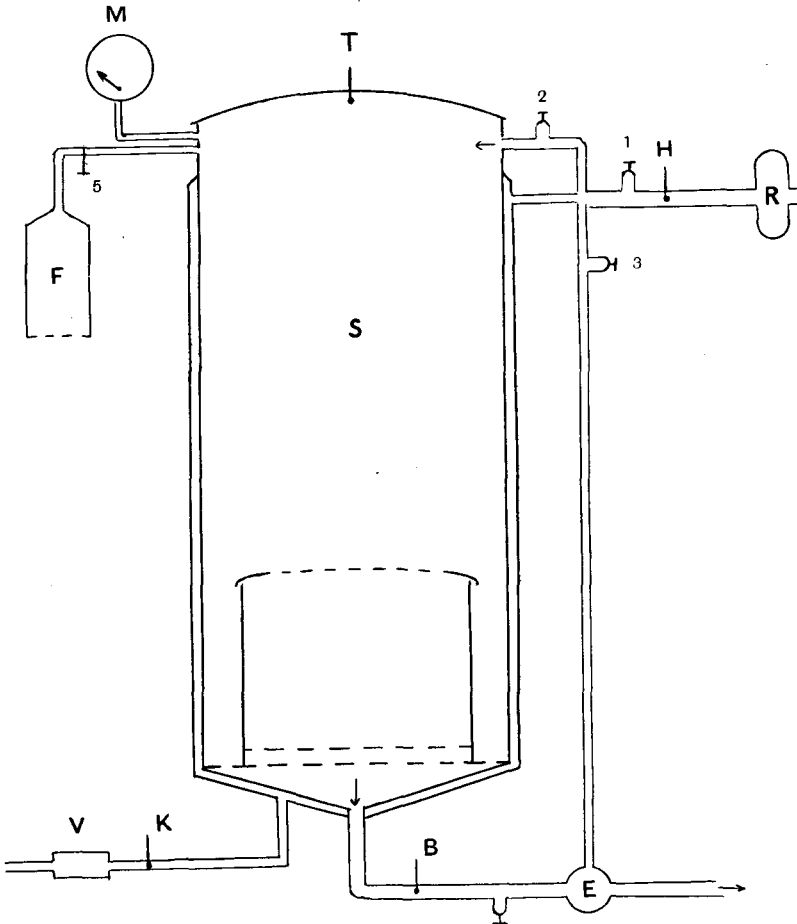

Fig. 1.

The streaming of steam through the jacket was regulated automatically during the preliminary heating, sterilising, and subsequent drying, by a water outlet.

The steriliser was provided with a metal filter (*F*) filled with unabsorbent cotton for filtering the air passing through chamber (*S*) when, during the drying, air is sucked into the chamber and through it by means of a steam ejector (*E*) which acted on the bottom discharge of the chamber (*S*). This

could produce a vacuum in the steriliser of 250 to 300 mm. The ejector could be used only at a pressure of 2 atm. and not in experiments with steam at a pressure of 0.5 atm.

The steriliser's four thermometers (*H*, *T*, *K*, *B*) were frequently controlled at 100° in a flask (Fig. 2) by comparison with a certified normal thermometer (graded in half degrees, error $\leq 0.1^\circ$). The scales of the thermometers extended from 24° to 150° and were graded to 2°. The error, after the reading and correction of the steriliser's thermometers, was $\leq 0.5^\circ$.

The steriliser's manovacuummeter was checked by a check manometer¹ with double scales as used by factory inspectors. In the 110° experiments at a pressure of 0.5 atm. a sensitive manometer² was used with a scale showing from 0 to 2 atm. pressure, divided by 20 dividing lines.

By "preliminary heating" is understood the heating of the closed steriliser by the steam jacket alone.

By "sucking" is understood the use of the ejector on the "quite open" bottom cock.

By "blowing" through the steriliser, is understood the blowing of steam into the chamber *S* while at the same time the ejector is used on the "quite open" bottom cock.

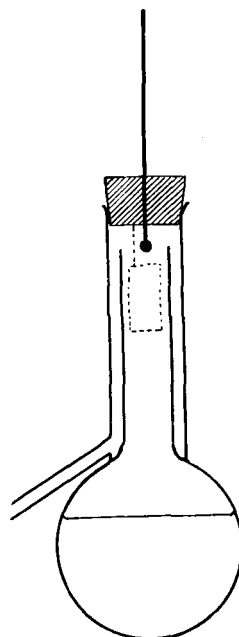

Fig. 2.

Sterilisation buckets.

For the experiments, cylindrical copper sterilisation buckets (Fig. 3) with overlapping lids were used. The lids and bottoms were perforated with holes 12 mm. in diameter, the lids with 22 holes, the bottoms with 49. The lids, where perforated, were double and here were inserted bacterial filters consisting of layers of unabsorbent cotton between two pieces of filter-paper. The holes at the bottom were likewise covered with a layer of unabsorbent cotton and a piece of filter-paper above and below.

The inside measurements of the buckets were, height 205 mm., diameter 280 mm. The bottom was slightly arched and the drum (or sides) of the bucket extended 15 mm. below the bottom, forming a support. If several buckets were in the steriliser at one time, they were placed on top of each other and with a little space between, to allow of the steam forcing its way in between them. The sides of the buckets were not perforated.

Contents of buckets. The buckets were packed with three kinds of contents, either with four surgeon's smocks, or 25 pieces of cellulose-matter or eight pieces of wax-cloth plus eight pieces of tow-cloth. One smock bucket (*S*

¹ Manufactured by C. Wilh. Stem Sohn, Hamburg.

² Manufactured in accordance with Courdon's System.

bucket) contained four smocks (*i.e.* an outer garment worn by surgeons when operating, made of a closely woven cotton drill) plus two "makosan" (roughly woven cotton, resembling wool) sleeves totalling 2400 gm. A cellulose-matter bucket (*C* bucket) contained about 25 pieces of compressed cellulose-matter weighing about 1200 gm. A wax-cloth bucket (*W* bucket) contained eight pieces of wax-cloth (black, 500 × 800 mm.) folded, each by itself, with a piece of tow-cloth "diaper-stout" (700 × 900 mm.), into parcels of 40 × 200 × 280 mm., in all, eight parcels weighing about 1900 gm. (of which about 1000 gm. were wax-cloth).

The contents of the buckets were packed in horizontal layers, slightly tighter than usually done in hospital. In some series of experiments, "perpendicular packing" was employed, so that the edges of the parcels were towards the lid and bottom while the parcels, in the case of "horizontal packing," lay in horizontal layers on top of each other. The packing was done as uniformly as possible, the entire space in the buckets being utilised so that there was no waste space nor any short cut passage for the steam. (This could not, however, be avoided in the *W* buckets.)

By weighing before packing, care was taken that the contents of the buckets were equally dry every day, and changes were almost always made between the series of experiments.

To get a measure of the water condensed in the contents of the buckets during the sterilisation, the latter were weighed immediately before and after the sterilisations, after wiping away the drops outside (least weight 1 gm.).

During the packing, 9 to 12 paper capsules of powdered earth and an equal number of maximum thermometers were distributed in each bucket, one thermometer with each sample of earth. The distribution may be seen in Fig. 3, where six of the samples (*a*, *b*, *c*, *d*, *e*, *f*) are placed peripherally, and six (1, 2, 3, 4, 5, 6) evenly distributed in the contents of the bucket. As might perhaps have been foreseen, the most difficult to sterilise were the samples which lay a little below the middle of the bucket; therefore, several were placed here for the sake of further check. (In the *S* buckets, one of the samples of earth and the thermometer appertaining thereto were wrapped up further in a pair of "makosan" sleeves, which however seldom made any difference to the results.) In the *C* buckets, the samples were distributed evenly, about the same as in the *S* buckets, while in the *W* buckets, each piece contained its thermometer and a sample of earth, besides which, samples and thermometers were placed peripherally.

Samples of earth. For test objects, samples of earth were used, as stated already. They were prepared as follows. About 2 kg. of forest earth from

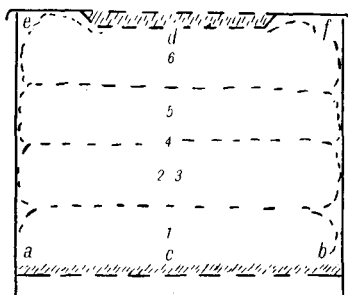

Fig. 3.

the deer park was dried at room temperature and pulverised. Stones were sifted out with a hair sieve and gauze, so that a fine powder was obtained. This was kept at room temperature in the dark, in a glass with an overlapping lid. The powder was packed in paper capsules (class II, No. 4) as used by chemists for powder, as much as would go on the point of a knife (say 7 to 10 cg.) in each capsule. Such capsules were used as test objects.

The resistance of the earth samples against steam-disinfection was tested by placing a capsule in a clip under the stopper of a flask (Fig. 2) by the side of a thermometer (Fig. 2, the dotted line). The capsule with its contents, was thus exposed to current steam at 100°. It was found that ample growth occurred in the broth and also anaerobic growth in agar stabs beneath an agar plug, even from capsules which had been exposed to current steam at 100° for one minute, but not from capsules that had been exposed to the same treatment for two minutes or more. The resistance did not alter noticeably in the course of the experiments. (Even though anaerobic growth did not come quite constantly from the capsules that had been exposed to current steam at 100° for one minute, a constant ample growth, both aerobic and anaerobic—occurred from all the capsules that had not been exposed to the action of steam, even from 2 cm. of powder.)

Media employed. The broth used contained 1 per cent. of albumen-peptone (Witte) and 0.5 per cent. NaCl; it was adjusted to pH 7.3 (S. P. L. Sørensen's method) and there were 5 c.c. in each tube.

The peptone-broth-agar used, contained 1.5 per cent. of agar, and was adjusted to pH 7.0 to 7.1. This was boiled in the water-bath for half an hour, immediately before use; there were 4–5 c.c. in each tube, and the plug was 3 or 4 cm. high.

Cultivation was made from each capsule, both in the broth and in agar stabs below the plug. The glowing platinum needle was cooled in the edge of the agar mass, the thereby slightly moistened needle was then dipped into the powdered earth, a portion of which adhered to it, and was then deposited in the agar mass by a perpendicular stab in the middle. The melted contents of another agar tube was poured on to this, as a plug. The rest of the contents of the capsule was simply emptied into a broth tube. The culture tubes remained in a thermostat for 3 days at 36.5°, and the results then read. Direct microscopical examinations were made from all the broth tubes showing growth. Furthermore, microscopical examinations were made of a fuchsin stained culture in by far the greater number of agar stabs with anaerobic growths. (In individual experiments, where there were pronounced anaerobic growths from several capsules from the same bucket, only a few of the tubes were microscopically examined. In the microscopical examinations, importance was attached only to the presence or absence of a bacterial growth. In almost all cases, it involved mixed cultures of spore-bearing bacilli.)

Maximum thermometers.

To check the temperatures attained in the sterilisation buckets, mercury maximum thermometers 100 to 110 mm. long were used; scale from 35° to 138°, divided into whole degrees. The thermometers were numbered and checked at 100° by comparison with the standard normal thermometer. The error in the individual thermometers on being read in a perpendicular position immediately after unpacking was $\leq 1^\circ$.

The thermometers did not alter in the course of the experiments.

II. THE EXPERIMENTS.

The process in each single experiment was as follows:

- (1) Packing of the buckets with the contents, samples of earth and thermometers.
- (2) Weighing the buckets with contents after packing.
- (3) Placing in the chamber.
- (4) Sterilising; reading every minute, the four thermometers and the manometer.
- (5) Weighing the buckets (plus the condensed water in them).
- (6) Unpacking of the buckets and reading the maximum thermometers.
- (7) Sowing the broth and agar with earth from the samples.

Usually, no subsequent drying was undertaken before the unpacking of the buckets; on the other hand, special experiments were made with a view to the efficiency of the subsequent drying.

A series of experiments.

An example of a series of experiments: steam at 134° and a pressure of 2 atm. was used. The empty "cold" oven (20° to 24°) was heated for 10 minutes, with the lid open, by current steam through the jacket, immediately before the experiments, to avoid the excessive condensation on its walls and to blow through the main pipe. Three buckets were placed in the steriliser, one *W* bucket at the bottom, one *S* bucket in the middle, and on top, one *C* bucket, all packed with thermometers and samples of earth. The oven was closed and the steam let into chamber *S* (cock 2), after the bottom cock (4) had been adjusted to "half open," *i.e.* for "current steam." Every minute, the four thermometers and the manometer of the steriliser were read. After 5 minutes, the supply steam was cut off, the oven opened, the buckets weighed and unpacked during the reading of the inserted thermometers. Next day, the experiment was repeated, but the streaming of steam lasted 10 minutes, the third day 15 minutes, the fourth day 20 minutes and so on, the eighth day 40 minutes, forming together a series of experiments.

Three objects were aimed at in each single series of experiments:

- (1) To determine the gradual rise of temperature in the buckets.
- (2) To determine the shortest time for the sterilisation of the samples of earth used.
- (3) To determine the moisture absorbed in the buckets.

Graphic representation.

Within each single series of experiments, the time only was varied and the results could therefore be recorded graphically in a coordinate system, with time as the abscissa (Fig. 4). For instance:—If, for every experiment, the lowest of the measured temperatures in the *S* buckets was set down as the

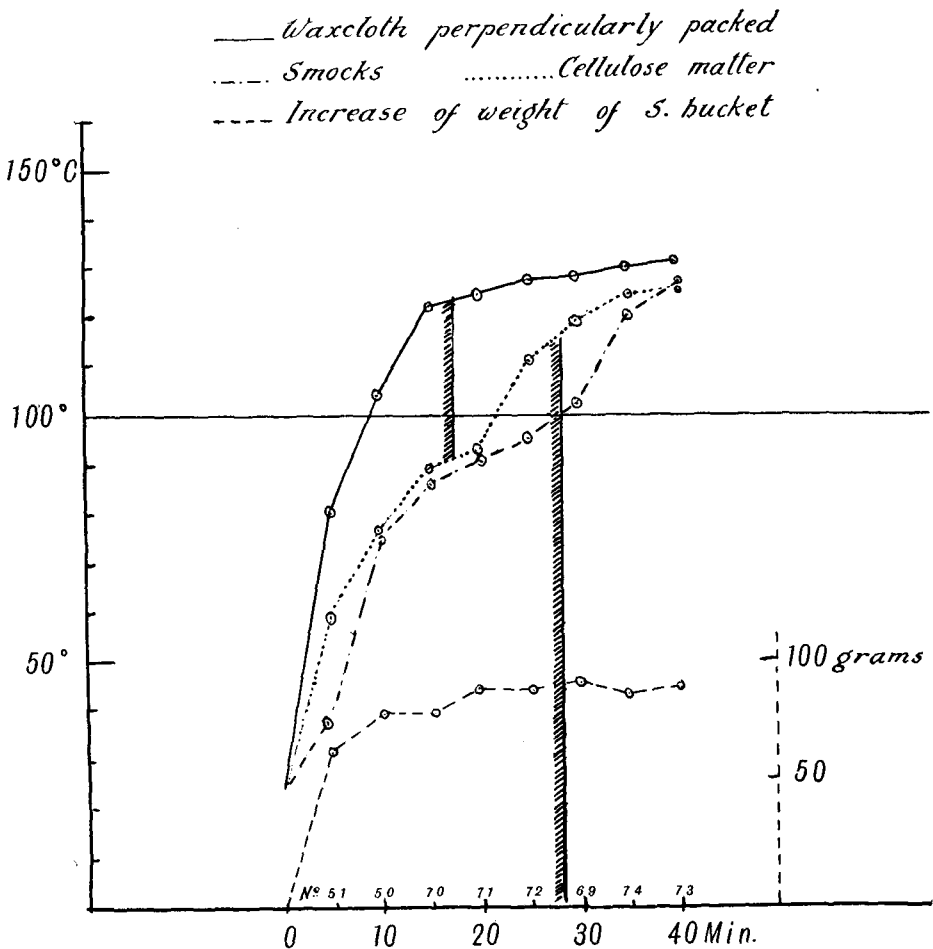

Fig. 4.

ordinate, the minute figure as the abscissa, a curve drawn through the eight points thus found would show how the temperature rose at the place in the *S* bucket, which was most difficult to heat when the bucket was exposed to current steam at a temperature of 134° (2 atm. pressure). Another curve drawn through the points, with the increase of weight as the ordinate would be an expression of the moisture absorbed. The results of the cultivations might be introduced as a hatched line at right angles to the abscissa, midway

between the number of the last experiment with, and of the first experiment without, growth in the broth. Similar curves might be drawn for *C* and *W* buckets.

The necessary experiments (as a rule eight) for the production of such a curve system, constitute a series of experiments. A curve system was an expression of the results obtained by a definite way of using the oven and could be compared directly with a curve system based on the results of a similar series of experiments, where one step in the instructions for the use of the steriliser had been altered. In the second series of experiments, there was used, for example, steam at 110° instead of at 134°—or 10 minutes were employed in sucking out the air contained in the steriliser before the steam was blown into the sterilising chamber—or 30 minutes' preliminary heating of the chamber and its contents by means of the steam jacket, etc.

Series of experiments were accordingly made to ascertain the significance of:

- (1) the preliminary heating of the oven and its contents;
- (2) the sucking out of the air before blowing steam into the *S* chamber;
- (3) the streaming of the steam;
- (4) the degrees of pressure (0.5 atm. at 110°; 2 atm. at 134°);
- (5) the nature of the contents of the buckets (hygroscopic and porous: cellulose-matter and surgeons' smocks; impermeable contents, *i.e.* wax-cloth);
- (6) the significance of the method of packing (perpendicular or horizontal in respect to the direction of the current steam);
- (7) the significance of the size of the steriliser.

Table I.

Steam temp. ° C.	<i>S</i> bucket	Samples of earth	Therm. registering lowest (° C.)	Increase of weight in grm.
134	*30 min. current steam	Sterile	103	92
134	35 min. current steam	"	121	86
134	*10 min. sucking out + 25 min. current steam	"	120	101
134	10 min. sucking out + 20 min. current steam	Not sterile	99	95
134	*30 min. prelim. heating + 25 min. current steam	Sterile	98	83
134	30 min. prelim. heating + 30 min. current steam	"	115	83
134	*10 min. current steam + 15 min. confined steam	"	96	96
134	10 min. current steam + 25 min. confined steam	"	99	84
134	10 min. current steam + 30 min. confined steam	"	112	86
134	*30 min. prelim. heat + 5 min. sucking + 5 min. blowing + 15 min. current steam	"	100	82
134	30 min. prelim. heat + 5 min. sucking + 5 min. blowing + 20 min. current steam	"	126	82
110	*40 min. current steam	"	109	110
	35 min. current steam	Not sterile	96	—
	<i>W</i> bucket			
134	*Horiz. packed 40 min. current steam	Sterile	112	75
134	*Perpend. packed 20 min. current steam	"	126	87
110	*Perpend. packed 30 min. current steam	"	103	90

* If less time was employed, the samples of earth were not sterile.

I have personally carried out 185 sterilisations, in 35 of which my new principle was applied.

From Table I the main points of interest in the results obtained from a portion of the series of experiments may be seen, since the *S* buckets are selected as an example, when nothing else is stated.

The bacteria employed in the work had, as described, a comparatively low resistance. It is therefore to be remarked that the results shown in the table are not the actual expression of the time necessary to produce sterility in a general way by the different directions for use in practice. The action of the steam must be prolonged by at least half an hour after 100° and sterility of the samples of earth have been attained, to produce "absolute sterility" of bucket like those used here.

III. RESULTS OF EXPERIMENTS.

In the following section, the principal results gained from the experiments are stated and a number of subjective assumptions are added in square brackets [].

Preliminary heating.

The preliminary heating of the steriliser and buckets has the effect of somewhat reducing the absorption of moisture in the contents of the buckets. After 30 minutes' preliminary heating of the chamber and its contents, the temperature registered by the top thermometer (*T*) was about 60°. The buckets themselves and the surfaces of the contents were heated to 50°, or 60° (from 22° or 24°), whereas there was no heating of the innermost layers. The temperature of the steam jacket itself was 130° to 134° during the preliminary heating.

As the surfaces which the intruding steam encounters after the preliminary heating are partially heated, the absorption of moisture was found to be about 10 gm. less in a *S* bucket which had been previously heated for 30 minutes, than in one which had not been thus heated.

The heating of the innermost portions was accelerated and the time for the action of the steam, necessary for sterilising the samples of earth, reduced by such preliminary heating by about 5 minutes.

The absorption of moisture occurs principally (80 gm. out of 90 gm.) (Fig. 4) during the first 10 minutes after the inrush of steam into the steriliser has begun, and almost exclusively in the uppermost layers in the buckets. As soon as the uppermost and outermost layers in the buckets are heated to the temperature of the intruding steam, only a slightly further increase in the weight of the buckets takes place, most probably because the heating in the inner layers proceeds almost without condensation.

The absorption of moisture is increased if the contents of the buckets are cooled before being placed in the steriliser.

Sucking out air.

The absorption of moisture is increased if the "sucking out" takes place before the steam is admitted into the *S* chamber (by 10 gm. per *S* bucket after "sucking out" for 10 minutes at minus 300 mm.). [On account of the increased expansion and the consequent formation of mist and because the mixture of mist and steam is brought so rapidly into contact with the contents of the buckets it penetrates further, as the air resistance is diminished.] (Before the steam came into the *S* chamber, it passed round the edge of a loose fitted inner lid, where the mixture of mist and steam was dried to some extent; the lid is not shown in Fig. 1.)

Preliminary heating for 30 minutes prevented the increased absorption of moisture produced by "sucking out" at minus 300 mm. for 10 minutes.

"Sucking out" for 10 minutes at 300 mm. vacuum, accelerated by 10 minutes the sterilisation and heating to 100° of the most difficult places in the *S* buckets.

"Sucking out" for 10 minutes, the last 5 minutes as "blowing" (*i.e.* "sucking out" during a simultaneous blowing in of steam with the bottom cock open) accelerated by from 10 to 15 minutes the sterilisation and heating to 100° of the most difficult places in the *S* buckets.

"Current steam."

If there were no atmospheric air in the steriliser and no absorption in the contents of the buckets, the streaming of steam would, presumably, not be necessary.

In an oven not provided with a powerful "sucking out" appliance (300 mm. vacuum is not enough) a certain current of steam is necessary, particularly at the commencement, to expel the air contained in the oven (at first the free air and later on the air absorbed by the contents of the buckets is gradually released).

"Current steam" at 110° (bottom cock at "half open") ensures that all the thermometers, in 40 minutes, reach temperatures of over 100°. With "current steam" at 134° for 10 minutes and further "confined steam" (bottom cock closed) for 30 minutes, the same temperature result was attained in the centre of the *S* buckets (the temperatures of the outmost layers were, of course, far higher when exposed to 134° than when exposed to 110° steam).

Considering the expulsion of air by a certain current of steam, a question arises as to the utility of an increase of the current. It should be borne in mind that steam follows the line of least resistance; even a porous object, like a *C* bucket or *S* bucket, acts against the streaming almost in the same way as a solid object, see Fig. 5 (*A*): the main stream of steam goes outside of the bucket, the contents of which are gradually heated as follows: (1) by condensation in the uppermost and outermost layer, (2) by hygroscopic absorption and condensation, (3) by intrusion; as the air contained in the

pores is compressed by reason of the pressure exerted by the steam, (4) and by a certain heat conductivity, particularly in moist places where the conductive properties of the cloth are increased on account of the water it contains. (Furthermore, the air sinks down on account of its specific gravity being greater than that of the steam.) An increased current of steam outside the buckets would hardly strengthen, to any extent, any of the above-mentioned

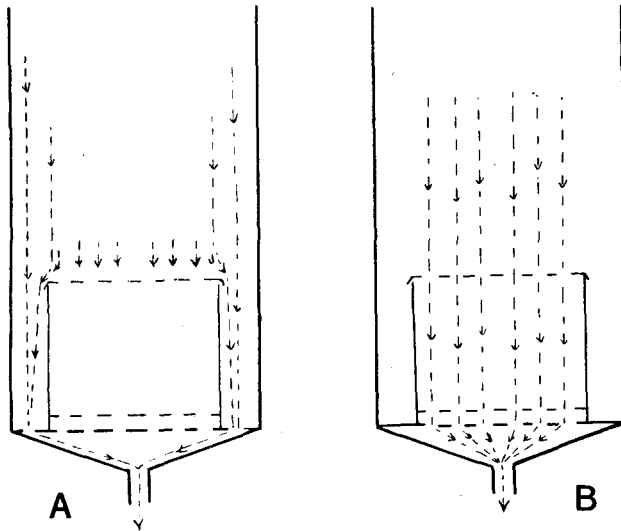

Fig. 5.

factors excepting the condensation with absorption of moisture in the outer layers. The inner layers in so large an object as an *S* bucket would only be slightly affected thereby. If the object has a low conductivity, cotton, atmospheric air and cellulose promote an increased passage of steam of a definite temperature to the surface, but not a more rapid heating in the inner layers, if the amount of heat which the conductive factors can manage to transport is already present in the outermost layers.

Pressure.

Steam at high pressure compresses the air in the pores of the contents of the buckets more than steam at a lower pressure and therefore penetrates deeper with the increase of the pressure when the inrush begins. If under the same conditions, in all other respects, current steam at 110° of 0.5 atm. pressure was used, instead of current steam at 134° of 2 atm. pressure, the time for heating was prolonged from 25–30 minutes to 35–40 minutes before the most difficult places in the *S* buckets had reached 100° . At the same time, it appeared that there were apparently 20–25 gm. more absorption in the *S* buckets with steam at 110° than at 134° in experiments of the same length of time. [Presumably, it depends exclusively on the following facts: When the

sterilisation is stopped and pressure within the oven ceases, both the buckets themselves, the outermost layers of the contents and the absorbed moisture therein is heated to a temperature of 134°–110° corresponding to that of the steam. When the pressure falls suddenly, because the steam in the oven is let out, a violent boiling away of a portion of the absorbed moisture will occur, involving a “spontaneous subsequent drying”—with a great consumption of heat. The consequent diminution of the moisture absorbed will be greatest in the experiments where the buckets and contents contain the greatest amount of heat beyond the 100° which corresponds to 1 atm. absolute pressure—consequently greater with 134° than with 110°, as the heat for re-evaporation is taken from the surroundings.]

The contents of the buckets. The properties of same and the mode of packing.

Of the hygroscopic materials (the cellulose matter and the surgeons' smocks) the latter were the most difficult to heat, owing most probably to their inferior hygroscopic properties. In heating wax-cloth, it must be taken into consideration that this takes place exclusively with condensation and conduction and that there are air spaces inside the parcels. “Streaming” therefore acquires a particular importance as regards wax-cloth. If the *W* buckets are packed horizontally and the pieces lie in layers on top of one another, the steam is compelled to go round about them, and only after a comparatively long action (*ca.* 35 minutes with current steam at 134°) do they become sterile and reach at least 100° in all places. With perpendicular packing, at least 104° in all pieces is reached in 10 minutes and sterility of the samples of earth at 120° is effected in 15–20 minutes (see Fig. 4). [That the wax-cloth must be raised to a comparatively high temperature to admit of the samples of earth being sterilised is due presumably to the air spaces in the parcels. In spite of these circumstances, the perpendicularly packed *W* bucket is always ahead of the *C* and *S* buckets, if current steam is used. Only by the application of the new principle, which is described below, can the *C* and *S* buckets derive so great a benefit that the *W* bucket is again the last to be heated and the last to become sterile under otherwise similar conditions.] The perpendicular packing of cellulose matter and surgeons' smocks has, on the other hand, no significance when, as is here the case, it is a matter of firm packing, as there is no intervening space for the steam; on the other hand, it would probably be of advantage to place mattresses on end in a disinfection oven, with small interspaces, instead of laying them in a heap.

The size of the steriliser.

A small steriliser was often more effective than a large one of the same construction, because in the latter, no attempt was made to increase the supply of steam in proportion to the larger capacity.

IV. DISCOVERY OF THE NEW PRINCIPLE.

When the experimental steriliser was considered to have been thoroughly tested, the intention was to investigate the significance of the size of the steriliser, and for this purpose, I used another steriliser of the same construction but smaller in size (height 550 mm., diameter 300 mm.; the supply pipe to the *S* chamber was of the same diameter as that of the experimental apparatus: 13 mm.). The oven, however, was not fitted with an ejector and had only just room for two superposed buckets.

A series of experiments was made with a *C* bucket and an *S* bucket, the latter being placed below directly on the perforated bottom plate of the chamber—on exactly the same lines as in the experiments recorded in Fig. 4. It then appeared that the *S* bucket in these experiments was heated far more rapidly than had hitherto been observed. After 10 minutes' supply of steam to the *S* chamber, the thermometer reading lowest in the *S* bucket registered 125° (about 76° was what had been expected, see Fig. 4). The thermometer in the *C* bucket giving the lowest reading, on the other hand, registered 86° (expected about 78°), that is, very near what was expected.

During none of the previous sterilisations (about 140) had so rapid a heating of *S* buckets been observed. In Fig. 4 it was not until after 40 minutes' current steaming that all the thermometers in the *S* bucket registered over 125°. Even after a preliminary heating for half an hour, "sucking out" for 5 minutes and "blowing through" for 5 minutes, a further "current steam" for 20 minutes was necessary to get all the thermometers in the *S* bucket to register over 125°.

With subsequent investigation, it seemed that the explanation was close at hand, though it took some time to clear up the matter. Apparently the placing of the *S* bucket was, in principle, different in the two sterilisers. In the experimental apparatus, the bucket was placed with a little interspace upon a *W* bucket carrying—also with an interspace—a *C* bucket. In the little steriliser, the *S* bucket carried in the same way a *C* bucket but was itself placed, like a tight lid, over *all* the holes in the bottom plate of the steriliser. The difference in principle may be seen in Fig. 5 where the mode of placing is schematically represented and the streaming of the steam is indicated with broken lines and arrows (to avoid confusion, only one bucket is shown in each of the two sterilisers of equal size). In *A* there is ample room for the steam to sweep round outside and then it gradually penetrates into the bucket and its contents. In *B* the steam is forced through the bucket by its own pressure, as there is no way of getting outside it (with a pressure of about 2 kg. per cm.)—all the holes in bottom plate being covered.

That it was actually the case as described was clearly shown by the fact that the arched bottom was pressed flat; in fact, it was bulging downward and the steam had, besides, forced holes through the lowest layer of the filtering paper, lying immediately at the bottom of the bucket.

The problem in the case of sterilising with steam is to fill the steriliser and the pores of its contents with saturated aqueous vapour at 100°–110° to 134° instead of atmospheric air, which acts as a most inefficient conductor and hinders the aqueous vapour from being effective.

The principle hitherto employed has been to place the materials to be sterilised in an atmosphere of saturated aqueous vapour and to allow this gradually to penetrate. As accelerating factors that are more or less effective, according to circumstances, are employed (*a*) streaming of the steam, (*b*) pressure of the steam, (*c*) “sucking out” of the air contained in the chamber, (*d*) preliminary heating of the steriliser and its contents, (*e*) loose packing.

The principle described here and schematically represented in Fig. 5 can hitherto hardly have been made use of consciously. The air contained in the chamber is forced through the pores of the contents of the buckets and is followed by the saturated aqueous vapour, which, on account of the pressure, acts almost like a plunger and is forced through all the pores in the contents of the bucket, because there is no other way. Presumably, the heating takes place exclusively by condensation.

That the cloth in a surgeon’s operation smock in this way offers but a comparatively slight resistance to a pressure like that of 2 atm., even if it is somewhat tightly packed—when there is no other egress for the steam—is perhaps less surprising when one recalls Pettenkofer’s experiment to prove the permeability of a brick, wherein he, with his “expiration pressure,” blew through a brick in accordance with a similar principle.

A very great volume of steam passes through the contents of the buckets. A pipe with an inside diameter of 13 mm. gives a free discharge of about 208 litres of steam at 134°, and 2 atm. pressure per minute.

The next thing to be thought of, was to make more complete the connection between the lower edge of the bucket—which formed its support—and the bottom of the chamber. A piece of india-rubber tube was therefore attached to the flange of the bottom of the bucket to act as packing. The perforated bottom plate in the experimental apparatus was then removed, so that the bucket could rest directly on the bottom of the steriliser, and it was then possible to obtain exactly the same results with this steriliser as hitherto with the smaller one. This was also tried with a *C* bucket and a perpendicularly packed *W* bucket, in both cases with excellent effect. The result may be seen in Table II.

In the experiments of Table II the preliminary heating of the steam jacket

Table II. *Experiments with current steam on samples of earth.*

Steam temp. ° C.	Buckets placed as per new principle	Therm. registering lowest (° C.)	Increase of weight in grm.
134	Samples from <i>C</i> bucket sterile after 5 min.	123	93
134	Samples from <i>S</i> bucket sterile after 5 min.	126	124
134	Samples from perpend. packed <i>W</i> bucket sterile after 10 min.	124	155
110	Samples from <i>S</i> bucket sterile after 5 min.	108	142

was not done as in Table I, where steam was passed through the jacket for 10 minutes, before the buckets were placed in the oven. The temperature of the jacket and chamber was therefore only 20°–24° at the beginning of the experiment. The new principle was then tested at 0.5 atm. pressure and 110°, two *S* buckets being placed in the experimental apparatus, the lower in accordance with the new principle and the upper as of old. The samples of earth in the lower bucket were sterile after 5 minutes (the thermometer registering lowest at 108°); the upper bucket was sterile after 30 minutes (the thermometer registering lowest at 102°). It must, however, be taken into consideration *that the strong current through the lower bucket to some extent shortened the time for the upper one, as it was placed rather closely over the lower one.*

In previous experiments, where *C*, *S* and *W* buckets were all placed according to the old principle and exposed to current steam at 110°, 40 minutes were necessary to sterilise the samples of earth in the *S* bucket (the thermometer registering lowest at 108°).

The new principle is hereby described and suggests the possibility of a new construction. How all the buckets in a steriliser are to be placed under the same favourable conditions is a technical problem, not dealt with here. Also with regard to the steam disinfection of mattresses, pillows and blankets, it is to be presumed that advantages may be gained in a steriliser, constructed according to the above principle.

The advantages claimed are the more rapid permeation of hygroscopic matter with saturated aqueous vapour than has hitherto been known. It has been made possible to use low pressure steam in steam sterilisers without the great prolongation of the time required for sterilisation which has otherwise been necessary. Besides the saving effected by diminished pressure and consumption of steam and more lightly constructed sterilisers, it ought to be possible to use smaller sterilisers than before, as the sterilisation is more rapidly accomplished. The packing of the buckets, according to the new principle, needs not to be so loose as before; it ought, in fact, to be tighter, but it must be uniform, so that the steam encounters a uniform resistance in the individual sections of the current. This latter is an irksome condition, though possible of fulfilment. Another defect in the system is, that the absorption of moisture per bucket becomes greater than during sterilisation in accordance with the hitherto employed principle, because the heating takes place almost exclusively by condensation. However, half an hour's subsequent drying, according to the new principle, is sufficient to remove entirely 125–130 grm. of absorbed moisture in an *S* bucket. By the old principle, only about 45 grm. of the usual 90 grm. of absorbed moisture in an *S* bucket were removed by subsequent drying for half an hour because the heated air passed outside of the bucket.

V. EXPERIMENTS WITH FORMALIN.

Finally, a brief description of a few orientating experiments for the employment of the principle to improve the formalin disinfection of porous objects will be given. The formalin-aqueous vapour was sucked through the *S* buckets as test objects.

The purpose was to induce a formalin disinfection working at a depth—to show that just as steam may be *blown* through an *S* bucket, formalin-aqueous vapours may be *sucked* through an *S* bucket. If by this means, one could obtain a permeation of porous matter with formalin-aqueous vapour, a method would, presumably, have been found which could be used for the disinfection of such articles as blankets, anthrax infected bales of hair, etc.

In a series of orientating experiments, it was also demonstrated that samples of earth contained in an *S* bucket placed in a large "Weimar" steriliser¹ can, in accordance with the new principle, be sterilised throughout at a low temperature by formalin. The Weimar apparatus referred to was a horizontal cylindrical one (length 2 m., diameter 1.5 m.). It was fitted below with an appliance for blowing in formalin-aqueous vapour and a piston air pump driven by electricity, which sucked through a pipe at the top of the chamber. This could produce a vacuum of 600–630 mm. in the oven, even during the simultaneous blowing in of formalin-aqueous-vapour. 1200 c.c. of formalin (35–38 per cent.) was blown in for 25 minutes during a simultaneous sucking. From the exhaust pipe above, an airtight flexible tube was carried to the tube of a tin funnel. On this funnel, stood the *S* bucket which was to be placed, in accordance with the new principle, and the sucking out therefore acted directly on the bottom of this bucket. Another *S* bucket stood beside the funnel as a check bucket; each of these buckets contained 12 maximum thermometers and 12 samples of earth as usual.

By means of a double-jacket system which could be heated by water or steam and a steam hot-case under the bottom of the chamber, the temperature in the steriliser was kept within certain limits. Experiments were made in which the temperature, during the 35 minutes' action of the formalin-aqueous vapour, did not exceed 81°, 71°, 68° (61°, 58°, 55°, and 51°). In the last four experiments, the sucking out to 625 mm. was done before the blowing in of the formalin began and was continued while it lasted. In these experiments, the heating of the walls of the chamber could not be done, therefore, a quantity of formaldehyde and aqueous vapour condensed and sank to the bottom, without having been effective. No subsequent drying or sucking out was employed. Immediately after the 35 minutes, the steriliser was opened and the buckets were unpacked. It was ascertained that the maximum thermometers had not exceeded the temperatures mentioned, afterwards cultivation was proceeded with as usual.

The results of the cultivation may be seen in Table III, where the number

¹ Gebr. Schmidt and Rich. Brauer, Weimar in Th.

of tubes with growth is recorded. These show that there is a distinct difference in the results from the check bucket and from the one standing on the funnel, in spite of the bad experimental conditions in the disproportionately large steriliser. By means of the new principle, there presumably is a possibility of

Table III. *Experiments with formalin.*

Temp. ° C.	Bucket on funnel		Check bucket	
	Broth	Agar-stab	Broth	Agar-stab
81	0	-	+ in 6 t.	-
72	0	0	+ in 11 t.	+ in 6 t.
68	0	0	+ in 11 t.	+ in 6 t.
61	+ in 1 t.	0	+ in 11 t.	+ in 9 t.
58	0	-	+ in 11 t.	-
55	+ in 6 t.	+ in 1 t.	+ in 12 t.	+ in 9 t.
51	+ in 11 t.	+ in 1 t.	+ in 12 t.	+ in 12 t.

0 = no growth in cultures.
 + = growth in cultures.
 - = not cultivated.
 t. = tubes.

removing the remains of the formaldehyde more effectively than previously by the direct forcing through of heated air or ammonia vapour.

Perhaps the principle described will attain its most important application from the very fact that it renders possible a deeply penetrating formalin disinfection at low temperatures.

SUMMARY.

- (1) A modern pressure steam steriliser is thoroughly tested systematically.
- (2) The experiences gained by the different methods employed are compared.
- (3) It is shown that if steam is *forced through* the objects to be sterilised, the penetration through and the heating of the materials are practically effected in the time it takes to fill the oven. A bucket containing four surgeons' smocks and placed in accordance with the new principle, is thus heated in 5 minutes from 24° C. to 126° C. in all layers, by steam at 134° C. (2 atm. pressure). The same bucket placed in current steam at 134° C. with space for the steam to stream round about the bucket, as in ordinary sterilisers, is to be steamed for 40 minutes to get the thermometers in the contents to register over 125° C. In the first case, the samples of earth used are sterile after 5 minutes, in the second, after 30 minutes.
- (4) In a series of orientating and purely provisional experiments, it is also proved that a smock bucket can be sterilised *throughout* at a low temperature, by formaldehyde-aqueous vapours, when these are sucked through the smocks, in accordance with the new principle.

My most cordial thanks are due to Professor L. S. Fridericia, M.D., and Head Surgeon A. Helsted, M.D., for working facilities, encouragement and scientific advice.

REFERENCES.

- BUDDE (1889). Die Bedeutung der Spannkraft, Temperatur und Bewegung des Dampfes bei Desinfektion in Dampfapparaten. *Arch. f. Hygiene*, **9**, 293.
- GLOBIG (1888). Ueber einen Kartoffel Bacillus mit ungewöhnlich widerstandsfähigen Sporen. *Zeitschr. f. Hygiene*, **3**, 322.
- GRUBER (1888). Erklärung der Desinfektionskraft des Wasserdampfes. *Centrabl. f. Bacteriol. u. Parasitenk.* **3**, 634.
- HUEPPE (1885). *Die Methoden der Bakterienforschung*, p. 7 (referring to PASTEUR (1860). De l'origine des ferments. *Compt. rend.* **50**, 849).
- KOCH, GAFFKY und LÖFFLER (1881). Versuch über die Verwendbarkeit heisser Wasserdämpfe zu Desinfektionszwecken. *Mitteil. a. d. Kaiserl. Gesundheitsamt*, **1**, 322.
- NÄGELI (1877). *Die niedern Pilze*, p. 210.
- RUBNER (1898). Zur Theorie der Dampfdesinfektion. *Hyg. Rundschau*, No. 8, p. 721.
- SAMBUC (1885). Désinfection par la vapeur. *Rev. d'hygiène*, p. 889.
- WALZ und WINDSCHEID (1886). Der neue Desinfektionsapparat in Düsseldorf. *Centrabl. f. allg. Gesundheitspfl.* **5**, 426.

(MS. received for publication 24. VI. 1929.—Ed.)