

Upper, down, two-sided Lorenz attractor, collisions, merging, and switching

DIEGO BARROS[†], CHRISTIAN BONATTI[‡] and MARIA JOSÉ PACIFICO[†]

[†] *Instituto de Matemática, Universidade Federal do Rio de Janeiro, Rio de Janeiro, Brazil*
(e-mail: diegosbarros@macae.ufrj.br, pacifico@im.ufrj.br)

[‡] *Institut de Mathématiques de Bourgogne, CNRS, Université de Bourgogne, Dijon, France*
(e-mail: bonatti@u-bourgogne.fr)

(Received 29 September 2022 and accepted in revised form 5 January 2024)

Abstract. We present a modified version of the well-known geometric Lorenz attractor. It consists of a C^1 open set \mathcal{O} of vector fields in \mathbb{R}^3 having an attracting region \mathcal{U} satisfying three properties. Namely, a unique singularity σ ; a unique attractor Λ including the singular point and the maximal invariant in \mathcal{U} has at most two chain recurrence classes, which are Λ and (at most) one hyperbolic horseshoe. The horseshoe and the singular attractor have a collision along with the union of 2 codimension 1 submanifolds which split \mathcal{O} into three regions. By crossing this collision locus, the attractor and the horseshoe may merge into a two-sided Lorenz attractor, or they may exchange their nature: the Lorenz attractor expels the singular point σ and becomes a horseshoe, and the horseshoe absorbs σ becoming a Lorenz attractor.

Key words: Lorenz-like attractors, strange attractors, singular flows, singular hyperbolic attractors

2020 Mathematics Subject Classification: 37C10, 37D45, 37G35 (Primary); 74H60 (Secondary)

1. Introduction

Lorenz presented in [30] an example of a parameterized 2-degree polynomial system of differential equations, as in equation (1), as a very simplified model for the convection of thermal fluid, motivated by an attempt to understand long-term weather forecasting. The concrete model can be stated as

$$(\dot{x}, \dot{y}, \dot{z}) = (10(y - x), 28x - y - xz, xy - 8/3z). \quad (1)$$

Numerical simulations for an open neighborhood of the chosen parameters suggested that almost all points in the phase space tend to a strange attractor, nowadays called the Lorenz

attractor. Ever since its discovery in 1963, the *Lorenz attractor* has been playing a central role in the research of singular flows, that is, flows generated by smooth vector fields with *singularities*, that is, points where the flow vanishes. However, Lorenz's equations turned out to be very resistant to rigorous mathematical analysis, from both conceptual (existence of a singularity accumulated by regular orbits prevents the attractor from being hyperbolic) as well as numerical (solutions slow down as they pass near the singularity, which means unbounded return times and, thus, unbounded integration errors) points of view [54]. Moreover, for almost every pair of nearby initial conditions, the corresponding solutions move apart from each other exponentially fast as they converge to the attractor. That is, the attractor is sensitive to the initial conditions. This unpredictability is a characteristic of chaos. Most remarkably, this attractor is robust: it can not be destroyed by any small perturbation of the original flow.

A very fruitful approach was undertaken, independently, by Afraimovich, Bykov, and Shil'nikov [1, 2], and by Guckenheimer and Williams [23, 62]. They constructed a geometric Lorenz attractor that reproduces the behavior observed by Lorenz. As an abstract object, the geometric Lorenz attractor is the inverse limit of a semiflow on a branched 2-manifold (with boundary). The flow has a singularity, on the boundary of the surface, and orbits leaving a neighborhood of this singularity follow either of two branches which return to (and are glued together along) an interval of branch points transverse to the stable manifold of the singularity. From the geometrical point of view, geometric Lorenz attractors are flows on the three-dimensional space that contain a singularity accumulated by regular orbits, that is, orbits γ where $X^t(x) \neq 0$ for all $x \in \gamma$ and $t > 0$. They have a natural cross-section given by a two-dimensional square crossed by all orbits of the flow inside the attractor except the singularity.

While the discovery of the Lorenz attractor leveraged fundamental developments in Dynamical Systems, the equations in equation (1) themselves have continued to resist all the attempts to prove that they exhibit a sensitive attractor. Bunimovich and Sinai [13, 51] have indicated a program that could prove that the Lorenz equations have a transitive attractor.

Rychlik and Robinson gave a proof for the so-called Shilnikov criteria [50] providing necessary and sufficient conditions for the birth of the Lorenz attractor from certain classes of codimension-3 bifurcation (codimension-2 bifurcations for systems with the Lorenz symmetry) [46, 47, 49]. From the bifurcation point of view, in addition to these results, we cite the works in [20, 28, 29, 32, 38, 39, 48].

A successful approach for the Lorenz flow was through rigorous numerics. Many authors have performed numerical simulations of these equations, and the book by Sparrow gives an account of many of these results proved in the 1970s [54]. Later, in this way, it was proved [25, 26, 34, 35] that the Lorenz system of equations exhibits a suspended Smale horseshoe [52]. It implies, in particular, the existence of infinitely many closed orbits. However, proving the existence of an attractor as in the geometric models is an even harder task. Indeed, one cannot avoid the fact that solutions slow down as they pass near the singularity, which, as said before, means unbounded return times and unbounded integration errors, see [54, 57]. This was finally settled by Tucker in [56, 57] around the turn of the century.

The theory of dynamical systems indicates that the way to analyze the equations in equation (1) is to prove that they possess a strong stable foliation. For the geometric model of the Lorenz equations proposed by Guckenheimer and Williams in [23, 62], an invariant C^1 strong stable bundle and the resulting strong stable foliation are assumed to exist. With this assumption, the theory of normally hyperbolic attractors allows one to show that an attractor exists. It also gives a criterion to check if it is transitive. Once the strong stable foliation is known to exist with the right set of expansion rates for one set of equations, then they persist for perturbations of the equations; see [23, 45, 60, 61] for a discussion of the geometric equations and the resulting attractor. Recently, in [53], the authors proved the existence of C^k -invariant foliations for Lorenz-type maps. Nowadays, in the literature, there is an expressive number of results about the Lorenz geometric attractor, both from the geometric as well as the measure-theoretic points of view, and we refer the reader to see [9, 10, 21, 22, 41, 58] and references therein.

In the 1990s, a breakthrough was obtained by Morales, Pacifico, and Pujals [37], following the very original ideas developed by Mañé in the proof of the C^1 stability conjecture [33]. They provide a characterization of robustly transitive attractors for three-dimensional flows, of which the Lorenz attractor is the more significant example.

After this seminal work, significant advances in this theory were achieved through the work of many authors, who gradually turned to the statistical and stochastic points of view of the Lorenz attractor, see [4–6, 8, 10–12, 17, 18, 31, 43, 44].

Taking into account that the divergence of the vector field induced by the system in equation (1) is negative, it follows that the Lebesgue measure of the Lorenz attractor is zero. Henceforth, it is natural to ask about its Hausdorff dimension. Numerical experiments give that this value is approximately equal to 2.062 (cf. [59]) and also, for some parameters, the dimension of the physical invariant measure lies in the interval [1.24063, 1.24129] (cf. [16]). In [3, 55], this dimension is characterized in terms of the pressure of the system and in terms of the Lyapunov exponents and the entropy concerning a good invariant measure associated with the geometric model. However, in both cases, the authors prove that the Hausdorff dimension is greater or equal than 2, but not necessarily strictly greater than 2. A first attempt to obtain the strict inequality was given in [36], where the authors achieve this result in the particular case that both branches of the unstable manifold of the singularity meet the stable manifold of the singularity. Finally, in [40], the authors prove that the Hausdorff dimension of a geometric attractor is strictly greater than 2.

Despite all this progress, we still are far from a topological classification of singular hyperbolic attracting sets in dimension 3. Moreover, there is also a huge gap in the understanding of unfolding parameterized families of singular hyperbolic attractors in any dimension.

The Lorenz attractor has a unique hyperbolic singularity, whose strong stable manifold $W^{ss}(\sigma)$ separates the stable manifold $W^s(\sigma)$ into components, called the upper and lower local stable sets of σ . One of these local stable sets is *disjoint* from the attractor. These properties are shared by the geometrical Lorenz model.

This paper was motivated by a question from Adriana da Luz to the second author. How can one construct a three-dimensional flow presenting a singular hyperbolic attractor, containing a unique Lorenz-like singularity σ , intersecting robustly upper and lower

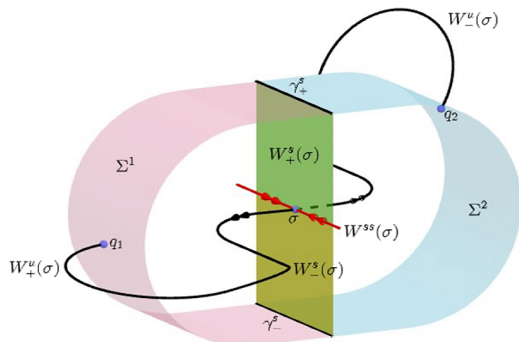

FIGURE 1. The diagram displays $\Sigma = \Sigma^1 \cup \Sigma^2$ and $W^s(\sigma) \setminus W^{ss}(\sigma) = W^s_+(\sigma) \cup W^s_-(\sigma)$, and the points $q_i, 1 \leq i \leq 2$, defined above.

local stable sets of $W^s(\sigma) \setminus W^{ss}(\sigma)$? One can easily construct examples exhibiting this phenomenon. Among those, a particular one displays a very intriguing behavior under perturbations. The goal of the present paper is to address this matter. That is, this work aims to build an open set of vector fields for which the attractors have intersections with the upper, lower, and both local stable sets.

We describe a C^1 -open set \mathcal{O}_1 of vector fields on a three-dimensional space having a common attracting region U which contains a unique singularity σ of Lorenz type, see Definition 2.3. As in the geometric Lorenz attractor, each flow $X \in \mathcal{O}_1$ has a global cross-section Σ , which is a topological annulus, and a first return map $P : \Sigma \rightarrow \Sigma$ possessing an invariant stable foliation \mathcal{F}^s . The intersection of the stable manifold of σ with the cross-section splits Σ into two connected components, Σ^1 and Σ^2 , and the intersection of the upper (lower) stable component of $W^s(\sigma)$ contains each a segment, γ^s_+ and γ^s_- , respectively, transverse to the boundary $\partial\Sigma$ and connecting the two boundary components of the annulus Σ . We denote the upper (lower) stable component of $W^s(\sigma) \setminus W^{ss}(\sigma)$ by $W^s_+(\sigma)$ ($W^s_-(\sigma)$), respectively, see Figure 1. We assume that both γ^s_+ and γ^s_- belong to \mathcal{F}^s . The unstable manifold of σ is one-dimensional and $W^u(\sigma) \setminus \{\sigma\}$ consists of two separatrices $W^u_i(\sigma), 1 \leq i \leq 2$, each one having a first intersection point q_i with Σ . See Figure 1.

The first result gives the topological nature of the class of flows in \mathcal{O}_1 , whose attractor intersects just one or both components of the stable sets of σ , proving the existence of three disjoint open and non-empty sets in \mathcal{O}_1 , roughly described as: \mathcal{L}^- , whose attractors intersect just $W^s_-(\sigma)$; \mathcal{L}^+ , whose attractors intersect just $W^s_+(\sigma)$; and $\mathcal{L}^{-,+}$, whose attractors intersect both $W^s_+(\sigma)$ and $W^s_-(\sigma)$. We call the attractors in \mathcal{L}^- *down-Lorenz*, the attractors in \mathcal{L}^+ as *upper-Lorenz*, and the attractors in $\mathcal{L}^{-,+}$ as *two-sided Lorenz*. We denote $\mathcal{L}^{-,+} \cup \mathcal{L}^+ \cup \mathcal{L}^- = \mathcal{L}$. See §4.4 for the precise definitions of these sets.

Now, let us explain what we mean by a fake horseshoe. It consists of a sequence of operations on the unit square, quite similar to the horseshoe, the only difference being the way back to the square of the resulting folded rectangle: the bottom of the folded rectangle fits back like the top of the starting square. Figure 2 displays the main features of a fake horseshoe. Note that a fake horseshoe preserves the orientation, while the horseshoe does not.

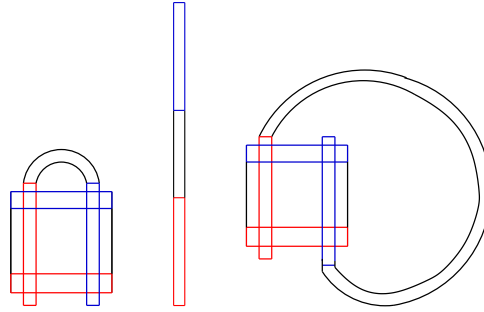

FIGURE 2. The usual horseshoe and a fake horseshoe.

THEOREM A. Any vector field $X \in \mathcal{L}^+$ admits exactly two chain recurrence classes: one is an upper-Lorenz attractor and the other is a hyperbolic basic set, topologically equivalent to the suspension of a fake horseshoe. The symmetric statement holds for \mathcal{L}^- , interchanging the upper for the down.

A saddle p (that is, a hyperbolic singularity point with non-trivial stable and unstable bundles) of a flow has a homoclinic tangency if its stable and unstable manifolds have some non-transverse intersection. In this case, we say that p has a homoclinic loop. Two saddles with different u-indices (that is, dimension of the unstable bundle) have a heterodimensional cycle if their stable and unstable manifolds intersect cyclically (by dimension deficiency, one of these intersections is necessarily non-transverse), see [15].

Two saddles of a C^1 vector field X are homoclinically related if the invariant manifolds of their orbits intersect transversely and cyclically. To be homoclinic related defines an equivalence relation on the set of saddles of X . Two saddles that are homoclinically related have the same u-index. The homoclinic class of a saddle p of X is the closure of the saddles of X that are homoclinically related to p . A homoclinic class is a transitive set (that is, it contains a point whose orbit is dense in the set).

Consider $\mathcal{H}^i \subset \mathcal{O}_1$, $i = 1, 2$, the hypersurface corresponding to the vector fields X for which the first intersection point q_i of $W_i^u(\sigma)$ with Σ belongs to $\gamma_+^s \cup \gamma_-^s$. In other words, X belongs to \mathcal{H}^i if σ admits a homoclinic loop for the unstable separatrices $W_i^u(\sigma)$ so that the homoclinic loop cuts Σ at a unique point q_i (see Figure 1).

THEOREM B. For any $X \in \mathcal{O}_1$ in one of the hypersurfaces \mathcal{H}^1 or \mathcal{H}^2 , the maximal invariant in U is a transitive singular attractor meeting both stable sets $W_-^s(\sigma)$ and $W_+^s(\sigma)$.

The statement of the theorem above does not announce a two-sided Lorenz attractor, because the hypersurface \mathcal{H}^i , $i = 1, 2$, is not an open subset, and then the robustness of the transitivity is not ensured. We split each \mathcal{H}^i into two $\mathcal{H}^i = \mathcal{H}_+^i \cup \mathcal{H}_-^i$ according to $\{q_i \in \gamma_+^s\}$ and $\{q_i \in \gamma_-^s\}$, respectively. We then prove the following result, which characterizes the topological nature of the attractors for flows in the hypersurfaces \mathcal{H}_+^i and \mathcal{H}_-^i . There is still the case of a double homoclinic loop that occurs when both intersection

points q_1 and q_2 of the unstable manifold of σ with the cross-section fall in the same segment of the intersection of the upper (lower) stable component of $W^s(\sigma)$ with the cross-section.

We denote by $\mathcal{H}_+^{1,2}$ the collection of flows in \mathcal{O}_1 such that $q_1, q_2 \in \gamma_+^s$. Similarly, we denote by $\mathcal{H}_-^{1,2}$ the collection of flows in \mathcal{O}_1 such that $q_1, q_2 \in \gamma_-^s$, see Figure 22 later. Thus, both unstable separatrices of σ are homoclinic connections and are included in the same connected component of $W^s(\sigma) \setminus W^{ss}(\sigma)$. Clearly, $\mathcal{H}_+^{1,2}$ and $\mathcal{H}_-^{1,2}$ are codimension 2 submanifolds included in $\mathcal{H}^1 \cup \mathcal{H}^2$. The next result ensures that for $X \in \mathcal{H}^i$ out of $\mathcal{H}_+^{1,2}$ and $\mathcal{H}_-^{1,2}$, the transitivity of the attractor is robust, showing that the attractor is a two-sided Lorenz attractor.

THEOREM C. *If $X \in \mathcal{H}^i \setminus (\mathcal{H}_+^{1,2} \cup \mathcal{H}_-^{1,2})$, there is a neighborhood $\mathcal{U}(X)$ of X such that the maximal invariant set for every $Y \in \mathcal{U}(X)$ is a two-sided Lorenz attractor.*

Before we announce the next result, recall that $W_+^s(\sigma)$ ($W_-^s(\sigma)$) is the upper (lower) stable component of $W^s(\sigma) \setminus W^{ss}(\sigma)$ and the sets \mathcal{L}^+ , \mathcal{L}^- , $\mathcal{L}^{+,-}$, \mathcal{L} are as above.

THEOREM D. *For any $X \in \mathcal{L}^{+,-}$, the maximal invariant set in $\mathcal{U}(X)$ is a transitive singular hyperbolic attractor meeting $W_-^s(\sigma)$ and $W_+^s(\sigma)$. That is, it is a two-sided Lorenz attractor.*

From our construction, we get that every $X \in \mathcal{L}$ contains a robust attractor (that is, there exists an open neighborhood \mathcal{U} of X in the space of vector fields such that every $Y \in \mathcal{U}$ has an attractor). In addition to that, although the complement of \mathcal{L} in \mathcal{O}_1 is non-empty, it has an empty interior. Thus, the next step is to understand the reasons why an attractor stops intercepting just one component of $W^s(\sigma) \setminus W^{ss}(\sigma)$ and suddenly starts to intersect both (and *vice versa*).

We will see that this phenomenon occurs due to the appearance of certain types of homoclinic and heteroclinic connections related to the position of the intersection points q_1, q_2 of $W_i^u(\sigma)$ with the cross-section.

Recall that Σ is split into two connected components Σ^1 and Σ^2 , determined by the intersections of $W^s(\sigma)$ with Σ . Assuming that the first return map has an expansion rate greater than the golden number $\varphi = (1 + \sqrt{5})/2$, when q_i falls into Σ^j with $i \neq j$, the Poincaré map has a fixed point $p_i \in \Sigma^j$. Typically, a heteroclinic cycle arises when q_i belongs to the stable leaf W_j^s through p_j .

We denote by \mathcal{O}_φ the subset of flows in \mathcal{O}_1 for which the first return map has an expansion bigger than φ , note that $\Sigma \setminus (W_1^s \cup W_2^s)$ splits into two connected components Σ_- and Σ_+ , see Figure 3. Let $\mathcal{HE}_i \subset \mathcal{O}_\varphi$ be the subset of flows corresponding to the vector fields X for which $q_i \in W_j^s$. In other words, for $X \in \mathcal{HE}_i$, the unstable separatrix of σ corresponding to q_i is a heteroclinic connection with p_j . The subsets \mathcal{HE}_i are codimension 1 submanifolds of \mathcal{O}_φ .

THEOREM E. *For any $X \in \mathcal{HE}_1 \cap \mathcal{HE}_2$, there is a unique chain recurrence class, which is not transitive. Both Σ_- and Σ_+ are invariant by P . The maximal invariant set of the restriction of P to Σ^i , $1 \leq i \leq 2$, is transitive: every unstable segment in Σ^i has its iterates*

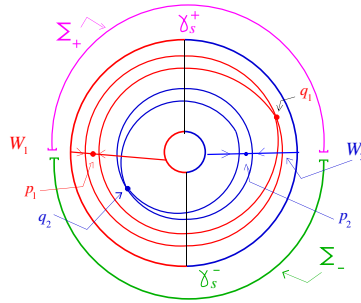

FIGURE 3. Σ_+ and Σ_- : determined by W_1 and W_2 , the stable manifolds of p_1 and p_2 , respectively.

which cut every segment in Σ^i . The open set U splits into two regions, each containing a full Lorenz (see Definition 2.9), intersecting along $W^s(p_1) \cup W^s(p_2) \cup W^u(\sigma)$. See Figure 20 later.

A similar construction for a full Lorenz was observed in [19] where it was called conjoined Lorenz twins.

The goal now is to describe the drastic changes in the behavior appearing in the topological dynamics when a family X_μ , $\mu = (\mu_1, \mu_2) \in [-1, 1]^2$, crosses the boundary of the regions considered in Theorems A, B, C, D, and E.

We can refine the analysis of the topological behavior of flows in \mathcal{O}_φ based on the position of q_1 and q_2 in Σ . This introduces a new region, denoted by $\widetilde{\mathcal{O}}_\varphi^{+,+}$, defined as the open subset where q_1 and q_2 belong to different components Σ_\pm and Σ_\mp .

The behavior of the topological dynamics in all these regions is established in the next theorem.

THEOREM F. *With the previous notation, we obtain the following:*

- the vector field X_μ belongs to \mathcal{L}^+ if and only if μ belongs to the quadrant $\mu_1 > 0, \mu_2 > 0$. In other words, the upper full Lorenz of $X_{0,0}$ becomes a (robust) Lorenz attractor, and the down full Lorenz of $X_{0,0}$ becomes a fake horseshoe;
- the vector field X_μ belongs to \mathcal{L}^- if and only if μ belongs to the quadrant $\mu_1 < 0, \mu_2 < 0$. In other words, the upper full Lorenz of $X_{0,0}$ becomes a (robust) Lorenz attractor, and the down full Lorenz of $X_{0,0}$ becomes a fake horseshoe;
- the vector field X_μ belongs to $\widetilde{\mathcal{O}}_\varphi^{+,+}$ if and only if μ belongs to the quadrant $\mu_1 < 0, \mu_2 > 0$ or the quadrant $\mu_1 > 0, \mu_2 < 0$. In other words, the two full Lorenz of $X_{0,0}$ merges into a two-sided Lorenz attractor.

The next theorem in the paper reads as follows.

THEOREM G. *With the previous notation, considering a 1-parameter family $X_{\mu=(\mu_1, \alpha\mu_1)}$ for some $\alpha > 0$, we obtain the following:*

- for $\mu_1 < 0$, the vector field admits a down Lorenz attractor and an upper fake horseshoe;

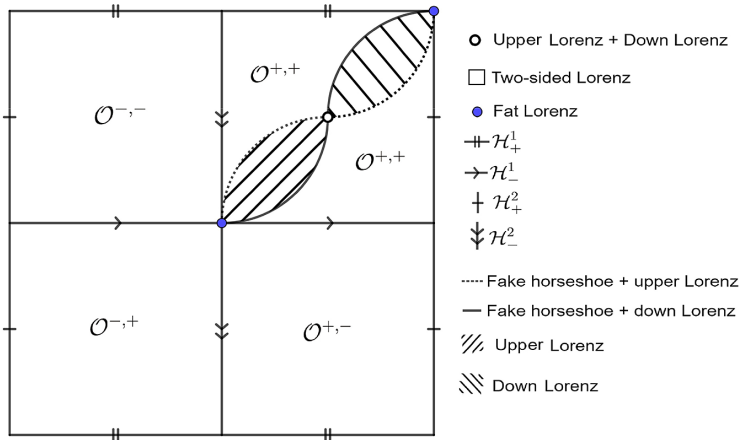

FIGURE 4. The bifurcation diagram of flows in \mathcal{O}_φ .

- when $\mu_1 = 0$, the fake horseshoe becomes a full Lorenz and, simultaneously, enters in collision with the upper Lorenz attractor, which becomes a full Lorenz;
- for $\mu_1 > 0$, the upper full Lorenz becomes a fake horseshoe when the down full Lorenz becomes a robust Lorenz attractor.

Figure 4 describes the main features established in Theorems F and G.

Next, we study in greater depth the topological nature of a flow in \mathcal{O}_1 . Recall that if $X \in \mathcal{O}_1$, then it contains a unique singularity σ of Lorenz type, see Definition 2.3. Moreover, X has a global cross-section Σ , which is a topological annulus and a first return map $P : \Sigma \rightarrow \Sigma$ possessing an invariant stable foliation \mathcal{F}^s . The leaves of the foliation \mathcal{F}^s are segments crossing Σ (connecting the two boundary components of Σ). The leaves space Σ/\mathcal{F}^s is a (topological) circle \mathbb{S}_X^1 . The segments γ_+^s and γ_-^s are leaves of \mathcal{F}^s and induce each a point c_+ and c_- respectively, on \mathbb{S}_X^1 . We assume that X preserves \mathcal{F}^s and thus the first return map P preserves the foliation \mathcal{F}^s . As a consequence, P passes to the quotient as a map $f = f_X$ defined from $\mathbb{S}_X^1 \setminus \{c_+, c_-\}$ to \mathbb{S}_X^1 . As in the geometric model, we will see that f_X restricted to each interval of $\mathbb{S}_X^1 \setminus \{c_+, c_-\}$ is a diffeomorphism.

As for the geometric model of the Lorenz attractor presented in [23], we will see that to any vector field in \mathcal{O}_1 , we can associate combinatorial data, called the itinerary of the discontinuities. These itineraries induce a semi-conjugacy of (Σ, P) with $(\mathbb{X}, \mathfrak{G})$, where \mathfrak{G} is the shift map on \mathbb{X} and \mathbb{X} is an appropriate alphabet chosen to represent the crossing points of the unstable manifold of the singularity with the cross-section.

Being precise, P is defined on $\Sigma \setminus (\gamma_+^s \cup \gamma_-^s)$ which is not invariant under P . Thus we get conjugacy in the restriction of $\Sigma \setminus W^s(\sigma)$. However, since the Poincaré map preserves a stable foliation and the itineraries for the Poincaré map are functions of the stable leaf, they pass to the quotient on the leaves' space, inducing itineraries for the one-dimensional quotient map. We use this symbolic analysis to show that each neighborhood of a flow in \mathcal{O}_1 , in the C^1 topology, contains flows whose attractor exhibits all of an uncountable

family of topological types. As in the case of the geometric Lorenz attractor, we prove that this phenomenon is co-dimension two stable. The topological types exhibited by the various versions of this example can be distinguished by two parameters. Moreover, we construct a two-parameter family of flows in \mathcal{O}_1 which is C^1 stable. This is the content of our last result below.

THEOREM H. *The restrictions to the maximal invariant sets of X and $Y \in \mathcal{O}_\varphi$ are topologically equivalent by a homeomorphism close to identity if and only if X and Y have the same itineraries.*

This paper is organized as follows. Section 2 gives the concepts, definitions, and results proved elsewhere that will be needed in the text. Section 3, constructs the open set of flows \mathcal{O}_1 that will be analyzed in the remainder of the text. Section 4 gives the background and auxiliary results to prove the main results. In §5, we prove Theorems A, D, B, C, and E. In §6, we prove Theorems F and G. In §9, we prove Theorem H.

2. Preliminaries

2.1. Basic topological notions. Let $\mathfrak{X}^r(\mathbb{R}^3)$, $r \geq 1$, be the space of vector fields defined on \mathbb{R}^3 , with the C^r topology. For $X \in \mathfrak{X}^r(\mathbb{R}^3)$, we denote by X^t the flow of X . If $U \subset M$, \overline{U} denotes the closure of U , $\text{int } U$ the interior of U , and ∂U the border of U . An invariant compact set Λ of X is *transitive* if there is $p \in \Lambda$ so that its positive orbit is dense in Λ (this notion is called *topological ergodicity* by some authors).

Recall that a sequence $\{p_i\}$ is an ε -pseudo-orbit for X if there is $t_i > 1$ such that $d(p_{i+1}, X^{t_i}(p_i)) < \varepsilon$ for all i . A point p is *chain recurrent* if for each $\varepsilon > 0$, there is a ε -pseudo orbit $p = p_0, p_1, \dots, p_n = p$. The recurrent chain set $\mathcal{R}(X)$ is the set of all chain recurrent points. It is a compact invariant set. An invariant compact set Λ is *chain recurrent* or *chain transitive* if for every $\varepsilon > 0$, it admits an ε -pseudo orbit $\{x_i\}$, $x_i \in \Lambda$, dense in Λ .

Two points p, q are chain equivalent if for any $\varepsilon > 0$, there are ε -pseudo orbits from p to q and from q to p . Conley's theory [14] proves that chain-equivalence is an equivalence relation whose equivalence classes are called the *chain recurrence classes*. They define a partition of $\mathcal{R}(X)$ by invariant pairwise disjoint compact sets. A compact region U is *attracting* for a vector field X of \mathbb{R}^3 if its boundary is a codimension 1 submanifold transverse to X and X is entering in U .

Definition 2.1

- A compact invariant set Λ_X of X^t is *attracting* if there exists an open neighborhood $U \supset \Lambda_X$ which is an attracting region and such that Λ_X is the maximal invariant set in U , that is,

$$\Lambda_X = \bigcap_{t>0} X^t(U).$$

- Λ_X is an *attractor* if it is attracting and chain transitive (in particular, Λ_X is a chain recurrence class).

- Λ_X is C^r robust if there is an attracting region $U \supset \Lambda_X$ such that Λ_Y is an attractor of Y for every vector field Y which is C^r close to X .
- An invariant compact set K is a *quasi-attractor* if it is a chain recurrence class and admits a basis of neighborhoods that are attracting regions. There is a decreasing sequence $U_i \subset U_{i-1}$ of attracting regions so that $K = \bigcap_i U_i$.

Notice that the existence of an attractor is not ensured *a priori*. However, Conley [14] proves the existence of quasi-attractors in any attracting region (for a vector field on a compact manifold).

Definition 2.2. Two vector fields X and Y defined on \mathbb{R}^3 are topologically equivalent if there exists a homeomorphism $h : \mathbb{R}^3 \rightarrow \mathbb{R}^3$ such that $h(\mathcal{O}_X(p)) = \mathcal{O}_Y(h(p))$ and for all $p \in M$ and $\varepsilon > 0$, there exists $\delta > 0$ so that for $t \in (0, \delta)$, there is $s \in (0, \varepsilon)$ satisfying $h(X^t(p)) = Y^s(h(p))$.

2.2. Singular points. A point p is singular if X vanishes at p , otherwise p is regular. The set of singular points of X is denoted by $\text{Zero}(X)$. A point $\sigma \in \text{Zero}(X)$ is hyperbolic if the real part of the eigenvalues of $DX(\sigma)$ does not vanish.

Definition 2.3. A singularity σ of X is Lorenz-like if the eigenvalues $\lambda_i \in \mathbb{R}$, $i \in \{s, s, u\}$, of $DX(\sigma)$ satisfy $0 < -\lambda_s < \lambda_u < -\lambda_{s,s}$.

Definition 2.4. In addition, σ is non-resonant if for all $N > 2$ and any choice of non-negative integer numbers m_1, m_2, m_3 with $2 \leq \sum_{j=1}^3 m_j < N$, we have $\sum_{j=1}^3 m_j \lambda_j \neq \lambda_i$.

Hartman Grobman’s theorem asserts that a vector field is locally topologically equivalent to its linear part in a small neighborhood of a hyperbolic singular point [24]. Then Sternberg provides conditions to guarantee that this local topological equivalence is true of class C^2 .

THEOREM 2.5. *Let X a vector field and let $n \in \mathbb{Z}^+$ be given. Then there exists an integer $N = N(n) \geq 2$ such that if A is a real non-singular $d \times d$ matrix with eigenvalues $\lambda_1, \dots, \lambda_d$ satisfying*

$$2 \leq \sum_{j=1}^d m_j < N \quad \text{and} \quad \sum_{j=1}^d m_j \lambda_j \neq \lambda_i$$

for any choice of non-negative integers $m_1, m_2 \dots m_d$, and if the application $X(v) = A(v) + \psi(v)$ and ψ is of class C^n for small $\|v\|$ with $\psi(0) = 0$ and $\partial_v \psi(0) = 0$, then there exists a C^N diffeomorphism from a neighborhood of $v = 0$ to a neighborhood of $\xi = 0$ that define a topologic conjugation between X and A .

Furthermore, the linearizing diffeomorphisms depend continuously on the C^2 topology from the vector field X , see for instance [42, Corollary in the Appendix] which provides a stronger statement.

2.3. *The shift map* \mathfrak{S} . We consider $\mathbb{X} = \{A_0, A_1, B_0, B_1\}^{\mathbb{N}}$ the space of infinite positive words in the alphabet $\{A_0, A_1, B_0, B_1\}$. We endow the alphabet $\{A_0, A_1, B_0, B_1\}$ with the total order $A_0 < A_1 < B_0 < B_1 < 1$. We endow \mathbb{X} with the corresponding lexicographic order that we denote by $<$ (and \preceq for the non-strict order). The shift map $\mathfrak{S} : \mathbb{X} \rightarrow \mathbb{X}$ is defined as

$$(w_j)_{j \geq 0} \in \mathbb{X} \mapsto \mathfrak{S}(w_j)_{j \geq 0} = (w_{j+1})_{j \geq 0}.$$

We also define the *star map* (denoted by \star) on \mathbb{X} as follows: given a sequence $w = (w_0, w_1, \dots) \in \mathbb{X}$ and a letter $L \in \{A_0, A_1, B_0, B_1\}$, we set $L \star w \stackrel{\text{def}}{=} (L, w_0, w_1, \dots)$.

2.4. Hyperbolic notions

Definition 2.6. Let X be a vector field of a manifold M . A compact invariant set $\Lambda \subset M \setminus \text{Zero}(X)$ is hyperbolic if the tangent bundle $TM|_{\Lambda}$ over Λ admits a splitting $TM|_{\Lambda} = E^s \oplus \mathbb{R}X \oplus E^u$ such that:

- the bundles E^s and E^u are continuous and invariant under the derivative of the flow;
- there exists $T > 0$ so that for all $p \in \Lambda$ and for all unit vectors $u \in E^s(p)$ and $v \in E^u(p)$, it holds $\|DX^T(u)\| < \frac{1}{2}$ and $\|DX^T(v)\| > 2$ (one says that E^s is *uniformly contracted* and E^u is *uniformly expanded*).

A hyperbolic invariant compact set K is called a *basic hyperbolic set* if it is transitive and admits a neighborhood on which it is the maximal invariant set. If K is a hyperbolic set, we denote $E^{cs} = E^s \oplus \mathbb{R}X$ and $E^{cu} = E^u \oplus \mathbb{R}X$, and these bundles are called respectively the weak stable and weakly unstable bundles.

Definition 2.7. A compact invariant set $\Lambda \subset M$ for X^t is *partially hyperbolic* if there exists a continuous and DX^t -invariant splitting $T_{\Lambda}M = E^s \oplus E^{cu}$ and constants $\lambda \in]0, 1[$, $K > 0$ such that for all $x \in \Lambda$ and $t \geq 0$, the following inequalities hold:

- $\|DX^t|_{E_x^s}\| \cdot \|DX^{-t}|_{E_{X^t(x)}^{cu}}\| \leq K\lambda^t$ (domination);
- $\|DX^t|_{E_x^s}\| \leq K\lambda^t$ (uniform contraction).

In addition, if E_{Λ}^{cu} is volume expanding, that is, $|\det(DX^t|_{E_x^{cu}})| > K e^{\lambda t}$ for all $x \in \Lambda$ and $t \geq 0$, Λ is, by definition, a *singular hyperbolic set*.

Note that any hyperbolic set is also partially hyperbolic. Notice that Λ_X an invariant compact set disjoint from $\text{Zero}(X)$ is partially hyperbolic if and only if it is hyperbolic. In dimension 3, if Λ_X is partially hyperbolic, then every singular point in Λ_X is a Lorenz-like singularity, see [37].

2.5. *Invariant manifold and foliations.* Let Λ be a compact invariant set for the flow X^t and $p \in \Lambda$. The stable $W_X^s(p)$ and unstable $W_X^u(p)$ sets at p are defined by

$$W_X^s(p) = \{q \in M : \text{dist}(X^t(q), X^t(p)) \xrightarrow[t \rightarrow +\infty]{} 0\},$$

$$W_X^u(p) = \{q \in M : \text{dist}(X^t(q), X^t(p)) \xrightarrow[t \rightarrow -\infty]{} 0\}.$$

If $\mathcal{O} = \mathcal{O}_X(p) \subset \Lambda$ denotes the orbit of $p \in M$, the stable set of the orbit of p is $W_X^s(\mathcal{O}) = \bigcup_{t \in \mathbb{R}} W^s(X^t(p))$. Analogously, the unstable set of the orbit of p is $W_X^u(\mathcal{O}) = \bigcup_{t \in \mathbb{R}} W^u(X^t(p))$.

If Λ is a hyperbolic set and p is a point in an orbit \mathcal{O} in Λ , then $W^s(p)$ and $W^s(\mathcal{O})$ are manifolds of the same regularity as X and are tangent (at p) to the stable bundle $E^s(p)$ and $E^{cs}(p)$, respectively. If Λ is partially hyperbolic, the stable sets of the points in Λ are submanifolds of the same regularity as X , tangent to E^s , and varying continuously with the point. Assume now U is an attracting region and that $\Lambda = \Lambda_U$, the maximal invariant in U , is a partially hyperbolic attracting invariant compact set. Let E^s denote the stable bundle defined over Λ . Then the bundle E^s always extends uniquely to U as an invariant bundle (still denoted by E^s) tangent to a topological foliation. Recently, Araùjo and Melbourne, [7, Theorem 4.12 and Remark 4.13(b)] provided bunching conditions ensuring the smoothness of the stable foliation, stated as follows.

THEOREM 2.8. [7, Theorem 4.12] *Let M be a differentiable Riemannian manifold of dimension 3, X a C^r vector field, U an attracting region, and $\Lambda \subset M$ a maximal invariant set in a U partial hyperbolic attracting set. Let $\{W_x^s\}$ denote the stable foliation in U . Let $q \in [0, r]$ and suppose that there exists $t > 0$ such that $\|DX^t|_{E_x^s}\| \cdot \|DX^{-t}|_{E_{X^t(x)}^{cu}}\| \cdot \|DX^t|_{E_x^{cu}}\|^q < 1$ for all $x \in \Lambda$. Then the foliation $\{W_x^s\}$ is of class C^q .*

2.6. Cone fields. Let $f : M \rightarrow M$ be a C^1 diffeomorphism and $T_x M = F^u(x) \oplus F^s(x)$ a continuous splitting. We define the stable and unstable cone fields of size $\gamma < 1$ as

$$C_\gamma^s(x) = \{(v_1, v_2) \in F^u(x) \oplus F^s(x) : \|v_1\| \leq \gamma \|v_2\|\},$$

$$C_\gamma^u(x) = \{(v_1, v_2) \in F^u(x) \oplus F^s(x) : \|v_2\| \leq \gamma \|v_1\|\}.$$

We say that C_γ^s (respectively $C_\gamma^u(x)$) is strictly invariant by Df^{-1} (respectively by Df) if there is $\alpha < 1$ such that $Df^{-1}(C_\gamma^s(f(x))) \subset C_{\alpha\gamma}^s(x)$ (respectively $Df(C_\gamma^u(x)) \subset C_{\alpha\gamma}^u(f(x))$).

Here, $\lambda_i \in \mathbb{R}$, $i \in \{s, s, u\}$, of $DX(\sigma)$ satisfy $0 < -\lambda_s < \lambda_u < -\lambda_{ss}$.

2.7. Geometric Lorenz attractor. Here we recall the construction of the geometric Lorenz model, following [23]. For more on this construction, the interested reader can consult [18] and [9, §3.3.2] for a detailed construction of this model. See Figure 5.

Let $S \subset \mathbb{R}^3$ and a parameterization such that $S = \{(x, y, 1) \mid x, y \in \mathbb{R} \text{ with } |x|, |y| \leq 1/2\}$. Let $\Gamma = \{(0, y, 1) \in S, |y| \leq 1/2\}$ and $\Sigma^\pm = \{(x, y, z) \mid x = \pm 1\}$.

Consider a C^1 -vector field X on \mathbb{R}^3 satisfying the following conditions.

- (1) For any point (x, y, z) in a neighborhood of the origin $(0, 0, 0)$, X is given by $(x', y', z') = (\lambda_1 x, \lambda_2 y, \lambda_3 z)$, where $0 < -\lambda_3 < \lambda_1 < -\lambda_2$.
- (2) For all $p \in S \setminus \Gamma$, there exist the smaller positive t_p such that $X^{t_p}(p) \in S$.
- (3) S is a cross-section to X and the first return map $P : S \setminus \Gamma \rightarrow S$ is a piecewise C^1 -diffeomorphism given by $P(x, y) = (f(x), g(x, y))$, satisfying: $f : [-1/2, 1/2] \setminus \{0\} \rightarrow [-1/2, 1/2]$ is piecewise C^1 map, $|f'| > \sqrt{2}$ where it is

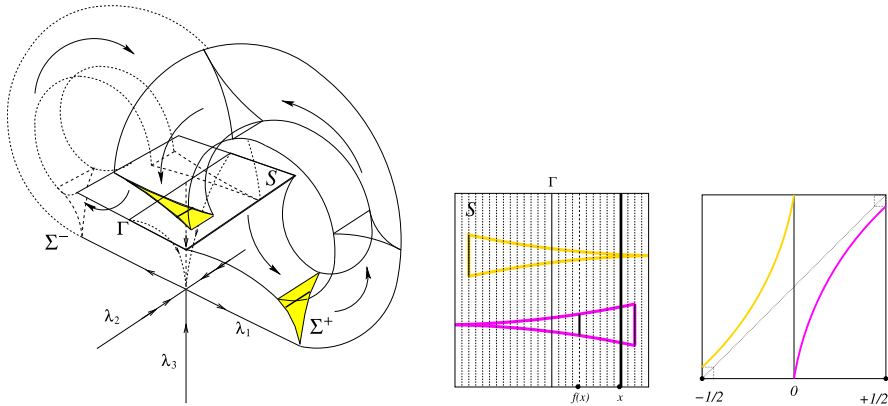

FIGURE 5. A geometric Lorenz flow, projection on I through the stable leaves; a sketch of the image of one leaf under the return map; and the one-dimensional map defined in the space of leaves of \mathcal{F}^S .

defined, $f(0^+) = -1/2$ and $f(0^-) = 1/2$, $|f'(0^\pm)| = +\infty$, and $\partial_y g(x, y) = Cx^\beta$ for $C > 0$ and $\beta > 1$.

Let X^t be the flow of X . The maximal invariant set $\Lambda = \bigcap_{t \leq 0} X^t(S)$ is called a geometric Lorenz attractor. Figure 5 describes the main features of the construction of a geometric Lorenz attractor.

Definition 2.9. A positively invariant region of a vector field X contains a full Lorenz Λ if it satisfies items (1) and (2) of the definition of Lorenz attractors above, but item (3) is replaced by the following.

- (3a) The first return map $P : S \setminus \Gamma \rightarrow S$ is a piecewise C^1 -diffeomorphism defined by $P(x, y) = (f(x), g(x, y))$, satisfying: $f : [-1/2, 1/2] \setminus \{0\} \rightarrow [-1/2, 1/2]$ is piecewise C^1 map, $|f'| > \sqrt{2}$ where it is defined, $f(0^+) = -1/2$ and $f(0^-) = 1/2$, $f(1/2) = 1/2$ and $f(-1/2) = (-1/2)$, $|f'(0^\pm)| = +\infty$, and $\partial_y g(x, y) = Cx^\beta$ for $C > 0$ and $\beta > 1$.

3. An open set of singular hyperbolic flows

We consider an open set \mathcal{O}_1 of vector fields X on \mathbb{R}^3 with the following properties described in the two next sections.

3.1. A geometric model for $X \in \mathcal{O}_1$

- (1) X has a Lorenz-like singularity $\sigma = \sigma(X)$ varying continuously with X and satisfying the Sternberg of non-resonance conditions. We set $W^s_+(\sigma)$ and $W^s_-(\sigma)$ for the connected components of $W^s(\sigma) \setminus W^{ss}(\sigma)$.
- (2) The vector field X is transverse to three embedded, disjoint annuli denoted by Σ , D^1 , and D^2 , see Figure 6.
- (3) For any point $p \in D^i$, there is $t(p)$ depending smoothly on p so that $X^{t(p)}(p) \in \Sigma$ and $X^s(p) \notin \Sigma \cup D^1 \cup D^2$ for $s \in]0, t(p)[$. In other words, $X^{t(p)}(p)$ is the first return of the orbit of p on $\Sigma \cup D^1 \cup D^2$, and we denote it by $R(p) = X^{t(p)}(p)$.

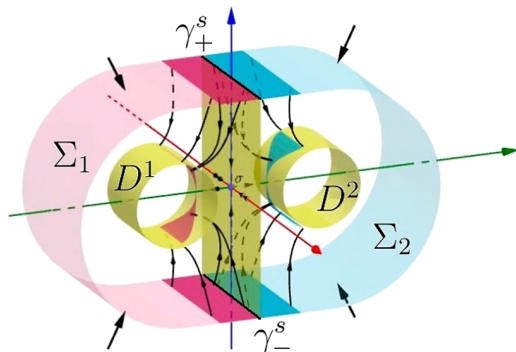

FIGURE 6. Trajectories of X crossing transversally Σ , D^1 , and D^2 .

- (4) Note R is a diffeomorphism from $D^1 \cup D^2$ to its image in Σ . In particular, $R(D^1)$ and $R(D^2)$ are annuli. We require that they are disjoint and each of them is an *essential annulus* in Σ (that is, it is not homotopic to a point).

Note that the union of the orbit segments $\bigcup_{p \in D^1} X^{[0, t(p)]}(p)$ is the product of the annulus D^1 by a segment. The same holds for D^2 .

- (5) $\Sigma \cap W_+^s(p)$ and $\Sigma \cap W_-^s(\sigma)$ contain each a segment, γ_+^s and γ_-^s , respectively, transverse to the boundary $\partial\Sigma$ and connecting the two boundary components of the annulus Σ . The positive orbits of points in γ_+^s and γ_-^s go directly to the singular point and are disjoint from $\Sigma \cup D^1 \cup D^2$. Then $\Sigma \setminus (\gamma_+^s \cup \gamma_-^s)$ consists of two components Σ^1 and Σ^2 . See Figure 6.
- (6) For any $p \in \Sigma^1 \cup \Sigma^2$, there is $t(p)$ depending smoothly on p so that $X^{t(p)}(p) \in D^1 \cup D^2$ and $X^s(p) \notin \Sigma \cup D^1 \cup D^2$ for $s \in]0, t(p)[$. Thus, $X^{t(p)}(p)$ is the first return of the orbit of p on $\Sigma \cup D^1 \cup D^2$, and we denote it by $S(p) = X^{t(p)}(p)$. Using item (3), one gets that $P = R \circ S: \Sigma \setminus (\gamma_+^s \cup \gamma_-^s) \rightarrow \Sigma$ is the first return map of X on Σ .
- (7) Let $W_1^u(\sigma)$ and $W_2^u(\sigma)$ denote the unstable separatrices of σ , that is, the connected components of $W^u(\sigma) \setminus \sigma$. Then the interior of D^i , $1 \leq i \leq 2$, contains the first intersection point \tilde{q}_i of $W_i^u(\sigma)$ with $\Sigma \cup D^1 \cup D^2$. Furthermore, $S(\Sigma^i) \cup \{\tilde{q}_i\}$ is an annulus pinched at \tilde{q}_i . This pinched annulus is essential in D^i (see Figure 7(a)): by pinched, we mean that in a neighborhood of \tilde{q}_i , the set $S(\Sigma^i) \cup \{\tilde{q}_i\}$ consists of two cuspidal triangles, with a cusp at \tilde{q}_i and tangent at this point to the same line but oriented in the opposite direction. By construction, the closure of $P(\Sigma^1 \cup \Sigma^2)$ consists of two parallel essential annuli in Σ , pinched at $q_i = R(\tilde{q}_i)$. See Figure 7(b).

3.2. Singular hyperbolic conditions

- (8) The maximal invariant set Λ in U is singular hyperbolic with bundles E^s and E^{cu} . This is equivalent to the request that the first return map P is hyperbolic. We will request more.
- (9) There is a cone field \mathcal{C}^u on the annulus $\Sigma \simeq \mathbb{S}^1 \times [-1, 1]$, transverse to the fibers $\{\theta\} \times [-1, 1]$, and strictly invariant by the derivative DP of P , and so that the

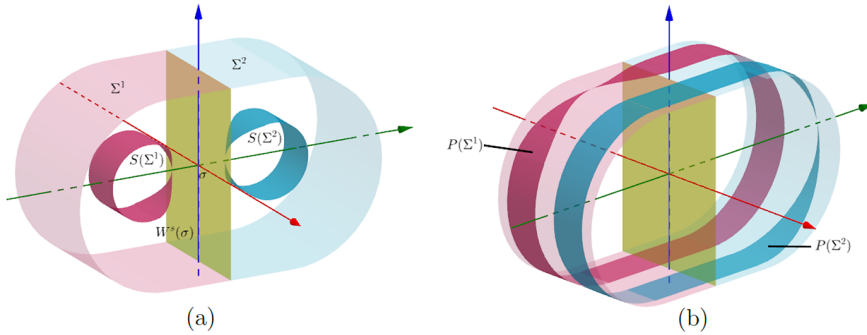

FIGURE 7. (a) The cross-section $\Sigma = \Sigma^1 \cup \Sigma^2$, and the images $S(\Sigma^1) \subset D^1$ and $S(\Sigma^2) \subset D^2$. (b) The image $P(\Sigma^1 \cup \Sigma^2) \subset \Sigma$.

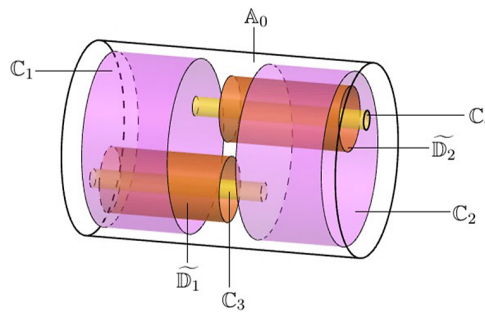

FIGURE 8. Determining the attracting region.

vectors in C^u are uniformly expanded by a factor $\lambda > 1$. The cone $C^u(p)$ has two components: vectors cutting the fiber positively or negatively.

- (10) There exists $t > 0$ such that $\|DX^t|_{E_x^s}\| \cdot \|DX^{-t}|_{E_{X^t(x)}^{cu}}\| \cdot \|DX^t|_{E_x^{cu}}\| < 1$ for all $x \in \Lambda$.

As a consequence of item (10) and [7, Theorem 4.12], the stable foliation is well defined in U and it is of class C^1 . This foliation is not tangent to Σ . However, there is a two-dimensional *center-stable foliation* well defined on $U \setminus \sigma$, obtained by considering the X^t orbits of the stable foliation: this foliation is C^1 too. This center stable foliation cuts the annulus Σ transversely along a C^1 , one-dimensional foliation \mathcal{F}^s , which is the stable foliation of the return map P . The segments γ_+^s and γ_-^s are leaves of \mathcal{F}^s . The foliation \mathcal{F}^s is transverse to the unstable cone field C^u . The leaves of the foliation \mathcal{F}^s are segments crossing Σ (connecting the two boundary components of Σ).

3.3. $X \in \mathcal{O}_1$ can be constructed in any three-dimensional manifold. To see that X satisfying items (1) to (10) can be realized in any 3-manifold, we first construct an attracting region $U \subset \mathbb{R}^3$ containing Σ , D^1 , D^2 , and the singularity σ so that every regular orbit of X in U crosses Σ transversally. The maximal invariant set Λ in U is an attracting invariant compact set (see Figure 8).

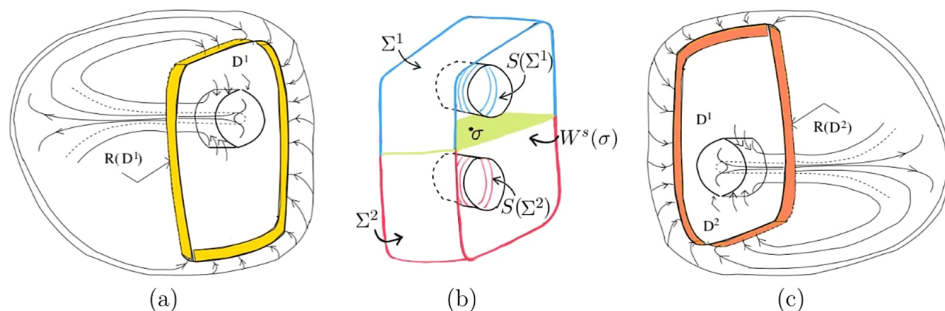

FIGURE 9. (a) Trajectories of X from D^1 to Σ , (b) the cross-section $\Sigma = \Sigma^1 \cup \Sigma^2$, and the images $S(\Sigma^1) \subset D^1$ and $S(\Sigma^2) \subset D^2$, (c) trajectories of X from D^2 to Σ .

To construct \mathbb{U} , we proceed as follows. Let $\mathbb{D} \subset \mathbb{C}$ be the unit disk in the complex plane and consider the solid cylinder $\mathbb{A}_0 = \mathbb{D} \times [-1, 1]$ with coordinates $z \in \mathbb{C}$ and $t \in [-1, 1]$. Define the solid cylinders

$$\begin{aligned} \mathbb{C}_1 &= \{(z, t); \|z\| < 1 - \varepsilon, t \in (-1 + \varepsilon, -\varepsilon)\} \quad \text{and} \\ \mathbb{C}_2 &= \{(z, t); \|z\| < 1 - \varepsilon, t \in (\varepsilon, 1 - \varepsilon)\}. \end{aligned}$$

Let $\mathbb{A}_1 = \mathbb{A}_0 \setminus (\mathbb{C}_1 \cup \mathbb{C}_2)$ and pick the points $x = 1/2, y = -1/2 \in \mathbb{C}$. Define

$$\begin{aligned} \widetilde{\mathbb{D}}_1 &= \{(z, t); \|z - x\| < 1/4, t \in (-1 + \varepsilon, 0)\} \quad \text{and} \\ \widetilde{\mathbb{D}}_2 &= \{(z, t); \|z - y\| < 1/4, t \in (0, 1 - \varepsilon)\}. \end{aligned}$$

Consider $\mathbb{A}_2 = \mathbb{A}_1 \cup (\widetilde{\mathbb{D}}_1 \cup \widetilde{\mathbb{D}}_2)$, and define

$$\mathbb{C}_3 = \{(z, t); \|z - x\| < 1/8, t \in (-\varepsilon, 1)\}, \quad \mathbb{C}_4 = \{(z, t); \|z - y\| < 1/4, t \in (-1, \varepsilon)\}.$$

Consider

$$\mathbb{U} = \mathbb{A}_2 \setminus (\mathbb{C}_3 \cup \mathbb{C}_4). \tag{2}$$

We define X in the interior of the region \mathbb{U} as follows. We can assume that the singularity σ is in the interior of \mathbb{U} and that its stable set $W^s(\sigma)$ intersects $\Sigma = \{(z, t) \in \mathbb{U} \times [-\varepsilon, \varepsilon]; \|z\| = 1 - \varepsilon\}$ into the two disjoint curves γ_-^s and γ_+^s that split Σ into two regions Σ^1 and Σ^2 . Let $D^1 = \{(z, t); \|z\| = 1/4, t \in (-\varepsilon/2, \varepsilon/2)\}$ and $D^2 = \{(z, t); \|z\| = 1/4, t \in (-\varepsilon/2, \varepsilon/2)\}$.

Define X in such a way that it crosses inward transversally Σ and, for each point $p \in \Sigma^1$ (respectively Σ^2), there is a first positive time t_p such that $X^{t_p}(p) \in D^1$ (respectively D^2). We set, to keep the previous notation, $X^{t_p}(p) \stackrel{\text{def}}{=} S(p)$.

Moreover, for each point $\tilde{q} = S(p) \in D^1$ (respectively D^2), there is a first positive time $t_{\tilde{q}}$ such that $X^{t_{\tilde{q}}}(q)$ crosses inward transversally Σ . Again, to keep the previous notation, we set $X^{t_{\tilde{q}}}(q) \stackrel{\text{def}}{=} R(\tilde{q})$. This completes the definition of X on the cross-section Σ . Clearly, Σ is a global cross-section to X and the first return map $P : \Sigma \rightarrow \Sigma$ is equal to $R \circ S$. Then we easily complete the definition of X on $\bigcup_{t \geq 0} \Sigma$ satisfying all the properties described above.

By construction, the region \mathbb{U} defined in equation (2) is homeomorphic to the attracting region for our flow X^t , and it is contained in \mathbb{R}^3 . Figure 9 represents the

geometric realization of the union $\bigcup_{p \in D^i} X^{[0, i(p)]}(p)$, where $1 \leq i \leq 2$. This illustration demonstrates that this construction can be realized within a ball contained in \mathbb{R}^3 and, consequently, within any three-dimensional compact manifold.

4. Topological dynamics: the attractor and the chain recurrence classes

Definition 4.1

- We say that $X \in \mathcal{O}_1$ exhibits a *two-sided (geometric model) Lorenz attractor* if for any Y in a neighborhood of X , the maximal invariant set Λ_Y in the attracting region U is transitive and has a non-trivial intersection with both stable sets $W_+^s(\sigma, Y)$ and $W_-^s(\sigma, Y)$.
- We say that X exhibits an *upper-Lorenz attractor* if it admits a geometric model of Lorenz attractor disjoint from the component W_-^s .
- We say that X exhibits a *down-Lorenz attractor* if it admits a geometric model of Lorenz attractor disjoint from the component W_+^s .

This section aims to show that, under a certain condition on the expansion in the unstable direction, the vector fields X in an open and dense subset exhibit either a two-sided or an upper- or a down-Lorenz attractor, and the three cases appear.

4.1. *Quasi-attractor.* We start by noticing that there is non-ambiguity on what can be the attractor.

PROPOSITION 4.2. *For any $X \in \mathcal{O}_1$, the chain recurrence class of the singularity σ is the unique quasi-attractor in the attracting region U .*

As U is an attracting region, Conley's theory implies that U contains at least one quasi-attractor. Now Proposition 4.2 is a direct consequence of the following lemma.

LEMMA 4.3. *The stable manifold of σ is dense in U .*

This proof is identical to the similar statement for the classical geometric model of the Lorenz attractor and is very simple. We include it here for completeness.

Proof. As any orbit cuts the cross-section Σ , we only need to prove that for any open set $O \subset \Sigma$, there is $n > 0$ so that $P^n(O) \cap (\gamma_+^s \cup \gamma_-^s) \neq \emptyset$.

We consider a segment $S \subset O$ such that for any $x \in S$, the tangent vector at $x \in S$ belongs to the cone \mathcal{C}^u . By item (9), there is $\lambda > 1$ so that the vector in \mathcal{C}^u is expanded by a factor larger than λ . Thus:

- either S cuts $(\gamma_+^s \cup \gamma_-^s)$ and we are done;
- or $P(S)$ is a segment tangent to \mathcal{C}^u whose length is at least λ times the length of S .

Iterating the process, one gets that either there is n so that $P^n(S)$ cuts $\gamma_+^s \cup \gamma_-^s$ or $P^n(S)$ is a segment tangent to \mathcal{C}^u whose length tends to infinity. As γ_+^s and γ_-^s are leaves of the foliation \mathcal{F}^s , which is a fibration by segments on the annulus Σ , there is a bound for the length of any segment in the unstable cone which does not cut every leaf, ending the proof. \square

4.2. *Iterating unstable segments and transitive properties.* We fix a vector field $X \in \mathcal{O}_1$, U is the attracting region in the definition, Σ is the global cross-section, and P is the first return map. First, notice that the closures $\bar{P}^n(\Sigma)$, $n \geq 0$, is a nested family of compact subsets of Σ . Let Λ_P denote the intersection of the $\bar{P}^n(\Sigma)$,

$$\Lambda_P = \bigcap_{n \geq 0} \bar{P}^n(\Sigma).$$

LEMMA 4.4. *The compact set Λ_P is the intersection of the maximal invariant set Λ_X with Σ . Furthermore, Λ_X is the union of σ with the saturated flow of Λ_P .*

Proof. Any orbit of Λ_X but σ cuts Σ . Any orbit but $W^u(\sigma)$ cuts Σ for an infinite sequence of negative times (tending to $-\infty$): indeed the α -limit set of such an orbit is not reduced to σ , and therefore cuts Σ . Thus, every orbit of Λ_X not in $W^u(\sigma)$ cuts Σ in $\bigcap_{n \geq 0} P^n(\Sigma)$. In Λ_P , we consider the closures $\bar{P}^n(\Sigma)$. This consists in adding $\Sigma \cap W^u(\sigma)$ to $\bigcap_{n \geq 0} P^n(\Sigma)$. The proof follows from these observations. \square

Note that for every $n > 0$, the closure $\bar{P}^n(\Sigma)$ consists in the union of 2^n pinched essential annuli, each annulus admits a finite set of pinched (cuspidal) points, and the boundary is tangent to the unstable cone. The intersection of two annuli is contained in this finite set of pinched points. Finally, the thickness of these annuli is exponentially decreasing with n . The intersection is an essential circle for any nested sequence of such pinched annuli in $\bar{P}^n(\Sigma)$, $n > 0$. In particular, the topological dimension of Λ_P is 1. Moreover, the boundary of any annulus is tangent to the unstable cone and the image by DP^n of this unstable cone. The intersection of the iterates of the unstable cones converges to a well-defined continuous, invariant line field E^u on Λ_P . Each of the circles is tangent to E^u .

LEMMA 4.5. *Let X be a vector field in \mathcal{O}_1 and P the first return map on the cross-section Σ . Suppose for every segment $S \subset \Sigma$ transverse to the stable foliation \mathcal{F}^s , the union of stable leaves through the iterates $P^n(S)$, $n \geq 0$, covers an open and dense subset of Σ . Then, the maximal invariant set Λ_X is transitive.*

One easily checks that is enough to prove the following lemma.

LEMMA 4.6. *Under the same hypothesis, given any non-empty open subsets $U \cap \Lambda_P$, $V \cap \Lambda_P$ (U and V open sets of Σ), there is $n > 0$ so that $P^n(V \cap \Lambda_P) \cap (U \cap \Lambda_P) \neq \emptyset$.*

Proof. The open subset $U \cap \Lambda_P$ contains a segment S_U tangent to the unstable cone. There is $\varepsilon > 0$ so that the segments of stable leaves through S_U (shrinking S_U if necessary) are contained in U . Let $W_\varepsilon^s(S_U)$ be the union of these segments. Note that for any $n > 0$, P^{-n} is defined on S_U up to a finite set (the first n iterates of the unstable manifold of σ). Now $P^{-n}(W_\varepsilon^s(S_U))$ contains the saturated by \mathcal{F}^s of $P^{-n}(S_U)$, which contains open segments in Λ_P . Consider now a segment S_V contained in $V \cap \Lambda_P$. By assumption, there is $m > 0$ so that $P^m(S_V)$ intersects stable leaves in $P^{-n}(W_\varepsilon^s(S_U))$. In other words, $P^{m+n}(S_V)$ cuts $W_\varepsilon^s(S_U)$ at points that belong to Λ_Σ (because S_V is contained in Λ_Σ ,

which is positively invariant by P). Thus, these intersection points belong to $U \cap \Lambda_\Sigma$ concluding the proof. \square

We now present tools to ensure that the orbit of an *unstable segment* (that is, a segment in Σ tangent to the unstable cone) cuts almost every stable leaf.

LEMMA 4.7. *Let S be an unstable segment joining a cuspidal point q_i in $\bar{P}(\Sigma)$ to a point q_\pm in γ_\pm^s . Assume that q_i belongs to Σ_i . Then there is $n > 0$ so that the union of the iterates $P^i(S)$, $i \in \{0, \dots, n\}$ cut every stable leaf but a finite number.*

Proof. The unstable cone is oriented, inducing an orientation over every unstable segment. Assume for instance that S is starting (for this orientation) at $q_i \subset \Sigma_1$ and ends on $q_- \in \gamma_-^s$: in particular, $S \subset \Sigma^1$. Now, $P(S)$ is an unstable segment ending at q_1 and of length $\ell(P(S)) \geq \lambda \ell(S)$. So $S_1 = P(S) \cup S$ is an unstable segment of length at least twice $\ell(S)$ and ending at q_- .

We define by induction a finite sequence S_n as follows: if S_{n-1} is contained in Σ^1 , then $S_n = P(S_{n-1}) \cup S$. Otherwise, the sequence ends and S_n is not defined. Thus, for every n , S_n is an unstable segment ending at q_- and of size at least n times the size of S . In particular, this sequence ends at some n_0 , and S_{n_0} is not contained in Σ^1 : it cuts γ_+^s . Now $P(S_{n_0})$ cuts every stable leaf up to one of q_1 . \square

Remark 4.8. In Lemma 4.7, the unique stable leaf which may not intersect the iterates $P^n(S)$, $n \geq 0$, is the leaf through q_1 . Furthermore, if q_1 is distinct from q_2 , then further iterates of S cut q_1 so that every leaf intersects some iterate of S .

LEMMA 4.9. *Assume now that Σ_i contains a fixed point p_i of P . Let S be an unstable segment whose interior cuts the stable leaf through p_i . Then there is n_0 so that for any $n \geq n_0$, the iterate $P^n(S)$ cuts every stable leaf but the one through q_i .*

Proof. By the inclination lemma (also known as λ lemma), the positive iterates $P^n(S)$ accumulate the unstable manifold $W^u(p_i)$. Some of these iterates will cross completely Σ^i (crossing both γ_+^s and γ_-^s). Then the next iterate will cross the whole essential pinched annulus $P(\Sigma_i)$, ending the proof. \square

4.3. Fixing the expansion rate bigger than the golden number $\varphi = (1 + \sqrt{5})/2$. For any flow $X \in \mathcal{O}_1$, the return map P is defined on the cross-section Σ but the two stable leaves γ_+^s and γ_-^s . So we get two rectangles and send them into Σ as a pinched essential annulus. Therefore, the expansion rate λ by P in the unstable cone cannot be required uniformly larger than 2. However, we will see that we can require a uniform rate expansion arbitrarily close to 2. Figure 10 displays the main features of the return map P .

The proof of the main topological properties consists of iterating unstable segments (tangent to the unstable cone) and estimating the length of these iterated components. In this section, we will choose a rate λ which will allow us to estimate these lengths. Let us start with a very elementary observation. Consider a segment $[a, c] \subset \mathbb{R}$ and pick $b \in]a, c[$. Then one of the lengths $\lambda^2 \ell([a, b])$ or $\lambda^2 \ell([b, c])$ is strictly larger than $\ell([a, c])$ if $\lambda > \sqrt{2}$. The choice of $\lambda > \sqrt{2}$ ensures the increase of a segment split into

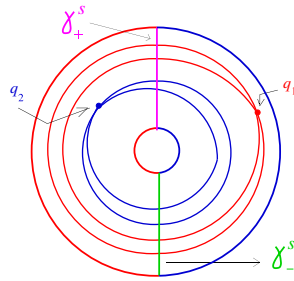

FIGURE 10. Another view of the cross-section Σ and the image of Σ under the Poincaré map.

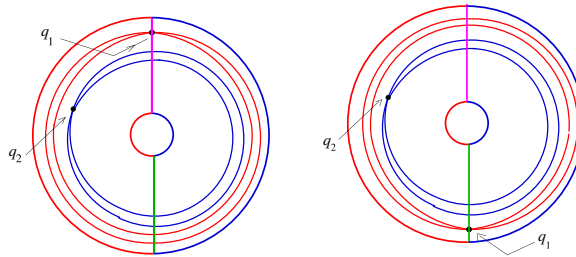

FIGURE 11. (a) $q_1 \in \gamma_+^s$ implying that $X \in \mathcal{H}_+^1$ and (b) $q_1 \in \gamma_-^s$ implying that $X \in \mathcal{H}_-^1$.

two components after two iterations if those components are not split again. This is the standard rate of expansion to guarantee the transitivity of a Lorenz attractor. We note that there are examples of one-dimensional Lorenz maps with a rate of expansion smaller than $\sqrt{2}$ that are not transitive, see [9, p. 126]. Consider the maximum of the lengths $\lambda\ell([a, b])$ and $\lambda^2\ell([b, c])$. Notice that the golden ratio $\varphi = (1 + \sqrt{5})/2 \in]1, 2[$.

LEMMA 4.10. *For any $a < b < c$, for any $\lambda \geq \varphi$, one gets $\max\{\lambda\ell([a, b]), \lambda^2\ell([b, c])\} \geq (\lambda/\varphi)\ell([a, c])$.*

Proof. Taking $\alpha = \ell([b, c])/\ell([a, c])$, we only have to show that $\max\{(1 - \alpha), \lambda\alpha\} \geq 1/\varphi$. For case $\alpha \geq (\varphi - 1)/\varphi$, we have $\lambda\alpha \geq \lambda((\varphi - 1)/\varphi) \geq \varphi((\varphi - 1)/\varphi) \geq (\varphi^2 - \varphi)/\varphi \geq 1/\varphi$ and we are done. However, if $\alpha < (\varphi - 1)/\varphi$, we get $1 - \alpha > 1 - ((\varphi - 1)/\varphi) = 1/\varphi$ and we are also done. \square

We consider now the open subset $\mathcal{O}_\varphi \subset \mathcal{O}_1$ consisting of flows X so that the expansion rate λ of the return map in the unstable cone is larger than φ .

4.4. *Cutting \mathcal{O}_φ in regions.* Consider $\mathcal{H}^i \subset \mathcal{O}_1$, $i = 1, 2$, the subset corresponding to the vector fields X for which the point q_i (first intersection with Σ of the unstable separatrix $W_i^u(\sigma)$) belongs to $\gamma_+^s \cup \gamma_-^s$. In other words, X belongs to \mathcal{H}^i if σ admits a homoclinic loop for the unstable separatrix $W_i^u(\sigma)$ so that the homoclinic loop cuts Σ at a unique point q_i . We split each \mathcal{H}^i into two $\mathcal{H}^i = \mathcal{H}_+^i \cup \mathcal{H}_-^i$ according to $\{q_i \in \gamma_+^s\}$ and $\{q_i \in \gamma_-^s\}$, respectively. Figure 11 displays the feature of a vector field $X \in \mathcal{H}^1$. It is well known that

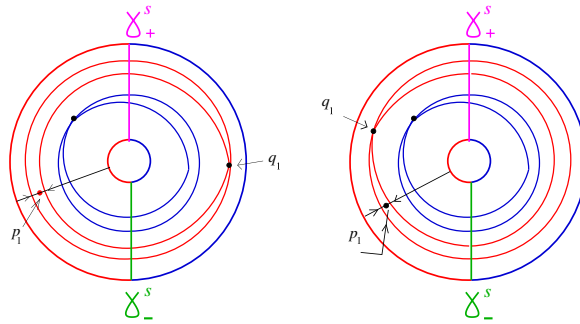

FIGURE 12. p_1 and p_2 are fixed points of $X \in \mathcal{O}_\varphi \setminus \mathcal{H}^1 \cup \mathcal{H}^2$.

a homoclinic connection corresponds to a codimension 1 phenomenon, as expressed in the following.

LEMMA 4.11. *The subsets \mathcal{H}^i are codimension 1 submanifolds of \mathcal{O}_1 .*

The submanifolds \mathcal{H}^1 and \mathcal{H}^2 cut \mathcal{O}_φ into 4 regions $\mathcal{O}_\varphi^{\omega_1, \omega_2}$, $\omega_i \in \{+, -\}$, so that $\omega_i = -$ if and only if $q_i \in \Sigma^i$. Then we have the following lemma.

LEMMA 4.12. *Let X be a vector field in \mathcal{O}_φ out of \mathcal{H}^1 and \mathcal{H}^2 . Then the first return map P admits a fixed point in Σ^1 (respectively Σ^2) if and only if X belongs to $\mathcal{O}_\varphi^{+,-} \cup \mathcal{O}_\varphi^{+,+}$ (respectively $\mathcal{O}_\varphi^{-,+} \cup \mathcal{O}_\varphi^{+,+}$).*

Proof. If $q_1 \in \Sigma^2$, it means that the cuspidal point of the pinched annulus $P(\Sigma^1)$ belongs to Σ^2 . Thus, $P(\Sigma^1)$ crosses Σ^1 in a hyperbolic way: Σ^1 is a rectangle with a stable boundary γ_\pm^s and its image $P(\Sigma^1)$ crosses completely Σ^1 along a sub-rectangle with a stable side contained in each of γ_\pm^s , leading to a unique fixed point in Σ^1 , see Figure 12(a). If $q_1 \in \Sigma^1$, then $\Sigma^1 \cap P(\Sigma^1)$ has two connected components which are cuspidal triangles T_1^+ (bounded by γ_+^s), T_1^- (bounded by γ_-^s). Assume that there is a fixed point p in T_1^- (for instance, the other case being equivalent). Then the region R bounded by γ_+^s and $W^s(p)$ is invariant by P , see Figure 12(b). However, $W^u(p)$ contains a segment joining p to γ_+^s . This segment is expanded by P , contradicting the invariance of R . This ends the proof. \square

Consider now the region $\mathcal{O}_\varphi^{+,+}$: every vector field $X \in \mathcal{O}_\varphi^{+,+}$ has exactly one fixed point p_1 in Σ^1 and one fixed point p_2 in Σ^2 . Let W_i^s be the stable leaf through p_i . Note that q_1 and p_2 are both in Σ^2 and in the same way, q_2 and p_1 are both in Σ^1 . This remark allows, *a priori*, that q_1 and p_2 belong to the same stable leaf or that q_2 and p_1 belong to the same stable leaf. This corresponds to our next splitting of the region $\mathcal{O}_\varphi^{+,+}$. Let us denote \mathcal{HE}_i as the subset of $\mathcal{O}_\varphi^{+,+}$ corresponding to the vector fields X for which $q_i \in W_j^s$. In other words, for $X \in \mathcal{HE}_i$, the unstable separatrix of σ corresponding to q_i is a heteroclinic connection with p_j , see Figure 13. As in Lemma 4.11, one has the following lemma.

LEMMA 4.13. *The subsets \mathcal{HE}_i are codimension 1 submanifolds of \mathcal{O}_φ .*

Consider $X \in \mathcal{O}_\varphi^{+,+} \setminus (\mathcal{HE}_1 \cup \mathcal{HE}_2)$. Then $\Sigma \setminus (W_1^s \cup W_2^s)$ has exactly two connected components: one, denoted by Σ_+ , contains γ_+^s , and the other, denoted by Σ_- , contains γ_-^s .

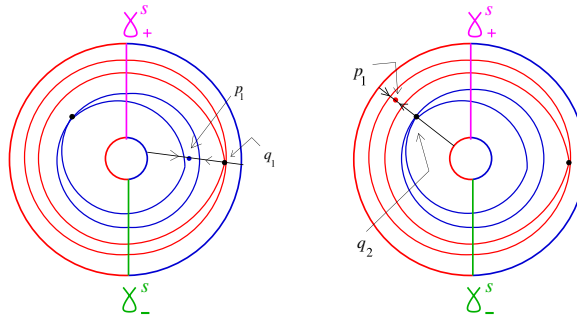

FIGURE 13. (a) $X \in \mathcal{HE}_1$ and (b) $X \in \mathcal{HE}_2$.

We denote by \mathcal{L}^+ the open subset of $\mathcal{O}_\varphi^{+,+}$ where both points q_1, q_2 belong to Σ_+ and \mathcal{L}^- the open set where both points q_1, q_2 belong to Σ_- . We denote by $\widetilde{\mathcal{O}}_\varphi^{+,+}$ the open subset where q_1 and q_2 belong to different components Σ_\pm and Σ_\mp . We will denote $\mathcal{L}^{+,-}$ as the union

$$\mathcal{L}^{+,-} = \mathcal{O}_\varphi^{-,-} \cup \mathcal{O}_\varphi^{+,-} \cup \mathcal{O}_\varphi^{-,+} \cup \widetilde{\mathcal{O}}_\varphi^{+,+} \cup ((\mathcal{H}^1 \cup \mathcal{H}^2) \setminus ((\mathcal{H}_+^1 \cap \mathcal{H}_+^2) \cup (\mathcal{H}_-^1 \cap \mathcal{H}_-^2))).$$

Recall that \mathcal{H}^i corresponds to a homoclinic loop and \mathcal{H}_\pm^i distinguishes the up or down connected components of $W^s(\sigma) \setminus W^{ss}(\sigma)$ involved in that loop.

5. The topological dynamics in the different regions of \mathcal{O}_φ

5.1. Upper- and down-Lorenz attractor: the regions \mathcal{L}^+ and \mathcal{L}^- . This section aims to prove the following result.

THEOREM A. *With the notation of §4.4, any vector field $X \in \mathcal{L}^+$ admits precisely two chain recurrence classes: one is an upper-Lorenz attractor and the other is a basic hyperbolic set, topologically equivalent to the suspension of a fake horseshoe. The symmetric statement holds in \mathcal{L}^- , interchanging the up and down.*

Proof. The component Σ_+ is a rectangle. The stable leaf γ_+^s cuts Σ_+ into two components. One is $\Sigma^1 \cap \Sigma_+$ and is bounded by $W_1^s = W^s(p_1)$ and the other is $\Sigma^2 \cap \Sigma_+$ and is bounded by W_2^s . Note that q_1 belongs to $\Sigma^2 \cap \Sigma_+$ and q_2 belongs to $\Sigma^1 \cap \Sigma_+$. Consider a stable leaf $L_1 \in \Sigma^1 \cap \Sigma_+$ separating W_1^s from q_2 , and a stable leaf $L_2 \in \Sigma^2 \cap \Sigma_+$ separating W_2^s from q_1 , see Figure 14. Then $L_1 \cup L_2$ cuts Σ^+ into three components: one is bounded by W_1^s another by W_2^s and the third, denoted by R_L , is a rectangle bounded by both L_1 and L_2 and containing q_2, q_1 and γ_+^s . The leaf γ_+^s cuts R_L in two components, $R_{L,1} \subset \Sigma_1$ and $R_{L,2} \subset \Sigma_2$.

Consider the restriction of P to $R_L \setminus \gamma_+^s$. The images of $R_{L,1}$ and $R_{L,2}$ are cuspidal triangles with cusps at q_1 and q_2 , and are contained in R_L . Recall that P is hyperbolic. Thus, the restriction of P to R_L satisfies all the properties of the return map in the geometric model of the Lorenz attractor with a rate expansion larger than $\varphi > \sqrt{2}$. The rectangle R_L is an attracting region for P . One deduces that U contains an attracting sub-region, in which X is a geometric model of the Lorenz attractor.

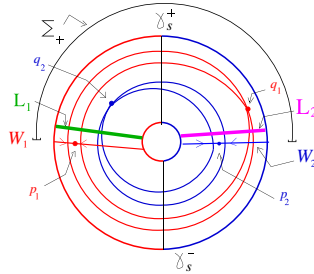

FIGURE 14. The leaves L_1 and L_2 , and the region Σ_+ .

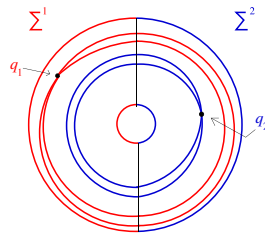

FIGURE 15. $q_1 \in \Sigma^1$ and $q_2 \in \Sigma^2$.

Consider now the component R_H of $\Sigma \setminus (L_1 \cup L_2)$ disjoint from R_L , and containing γ_-^s . Consider the restriction of P to $R_H \setminus \gamma_-^s$. The image of each of these components crosses R_H in a Markovian way. Thus, the maximal invariant in R_H is far from the discontinuity and is conjugated to the *fake horseshoe*, as the map P preserves the orientation of the unstable cone field. This ends the proof. The down case is similar. \square

5.2. Two-sided Lorenz attractor in $\mathcal{O}_\varphi^{-,-}$

PROPOSITION 5.1. *For any $X \in \mathcal{O}_\varphi^{-,-}$, the maximal invariant set in U is transitive and consists of a two-sided Lorenz attractor.*

Proof. According to Lemma 4.9, for proving the transitivity of the maximal invariant, it is enough to verify that the iterates of an unstable segment S in Σ cut all the stable leaves with the possible exception of a set with an empty interior, see Figure 15.

So consider an unstable segment $S \subset \Sigma$. Consider the set of lengths of the connected components of all positive iterates $P^n(S)$. If this set of lengths is not bounded, some component cuts every stable leaf, and we are done. Otherwise, given any $\delta > 1$, up to replace S by a segment in one of its iterates, one may assume that any connected component S' in any iterate $P^n(S)$ has a length bounded by $\delta \ell(S)$. We now fix $\delta \in]1, \lambda^2/2[$.

If S is disjoint from $\gamma_+^s \cup \gamma_-^s$, then $\ell(P(S)) > \lambda \ell(S) > \delta \ell(S)$ contradicts the choice of S . So S cuts γ_+^s or γ_-^s . If it cuts both, then it crosses completely Σ^1 or Σ^2 so that $P(S)$ cuts all the stable leaves but one, and we are done. So we may assume that S cuts exactly one of γ_+^s or γ_-^s , say γ_+^s , for instance. Let S_1 be a component of $S \setminus \gamma_+^s$ with a length larger or equal to $\frac{1}{2} \ell(S)$. The length of $P(S_1)$ is at least $(\lambda/2) \ell(S)$.

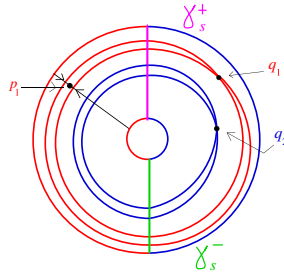

FIGURE 16. $q_1, q_2 \in \Sigma^2$ for $X \in \mathcal{O}^{-,+}$.

If $P(S_1)$ is disjoint from $\gamma_+^s \cup \gamma_-^s$, then

$$\ell(P(S_1)) > \lambda \ell(S_1) > \frac{\lambda^2}{2} \ell(S) > \delta \ell(S),$$

contradicting the choice of S . So $P(S_1)$ cuts γ_+^s or γ_-^s . Once again, if it cuts both of them, we are done, so one may assume that $P(S_1)$ cuts exactly one of γ_+^s or γ_-^s . Note that one of the endpoints of $P(S_1)$ is a cuspidal point $q_i \in \Sigma^i$ as $X \in \mathcal{O}_1^{-,-}$. Thus, Lemma 4.7 applies and concludes the proof of the transitivity of the maximal invariant set Λ_X . Note that the compact set Λ_P consists of a union of essential circles in Σ and therefore always cuts γ_+^s and γ_-^s , so that the maximal invariant set Λ_X intersects non-trivially both stable sets $W_+^s(\sigma)$ and $W_-^s(\sigma)$. Thus, Λ_X is a two-sided Lorenz attractor, ending the proof. See Figure 15. □

5.3. Two-sided Lorenz attractor in $\mathcal{O}_\varphi^{+,-}$ and $\mathcal{O}_\varphi^{-,+}$

PROPOSITION 5.2. *For any $X \in \mathcal{O}_\varphi^{+,-} \cup \mathcal{O}_\varphi^{-,+}$, the maximal invariant set in U is transitive and consists of a two-sided Lorenz attractor.*

The proof of the proposition for $X \in \mathcal{O}_\varphi^{-,+}$ is identical to the proof for $X \in \mathcal{O}_\varphi^{+,-}$ interchanging the components Σ^1 and Σ^2 , so we will write the proof only for $X \in \mathcal{O}_\varphi^{+,-}$. See Figure 16.

Proof. Recall that the rate of expansion of X is $\lambda > \varphi$.

As for Proposition 5.1, it is enough to prove that the iterates of an unstable segment S in Σ cut all the stable leaves with a possible exception of a set with an empty interior. See Figure 16. So consider an unstable segment $S \subset \Sigma$. Consider the set of lengths of the connected components of all positive iterates $P^n(S)$. If this set of lengths is not bounded, some component cuts every stable leaf, and we are done. Otherwise, given any $\delta > 1$, up to replace S by a segment in one of its iterates, one may assume that any connected component S' in any iterate $P^n(S)$ has a length bounded by $\delta \ell(S)$. We now fix $\delta \in]1, \lambda/\varphi[$.

If S is disjoint from $\gamma_+^s \cup \gamma_-^s$, then $\ell(P(S)) > \lambda \ell(S) > \delta \ell(S)$ contradicts the choice of S . So S cuts γ_+^s or γ_-^s . If it cuts both, then it crosses completely Σ^1 or Σ^2 so that $P(S)$ cuts all the stable leaves but one, and we are done.

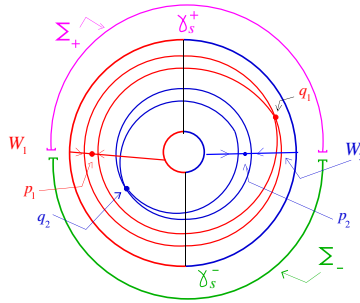

FIGURE 17. $q_1 \in \Sigma_+$ for $X \in \tilde{\mathcal{O}}_\varphi^{+,+}$.

So we may assume that S cuts exactly one of γ_+^s or γ_-^s , say γ_-^s , for instance. Thus, S is cut by γ_-^s into two components $S_i = S \cap \Sigma^i$. Consider $P(S_2)$. If $P(S_2) \cap (\gamma_-^s \cup \gamma_+^s) \neq \emptyset$, then Lemma 4.7 applies (because $q_2 \in \Sigma^2$ by our assumption $X \in \tilde{\mathcal{O}}_\varphi^{+,-}$). Thus, the iterate of S_2 cuts every stable leaf but a finite number of them so that we are done.

Thus, we may assume that $P(S_2)$ is disjoint from $\gamma_-^s \cup \gamma_+^s$. Hence, $P(S_2)$ is an unstable segment of length larger than $\lambda^2 \ell(S_2)$. However, $\ell(P(S_1)) \geq \lambda \ell(S_1)$. Now Lemma 4.10 implies that $\max\{\ell(P(S_1)), \ell(P^2(S_2))\} \geq (\lambda/\varphi)\ell(S) > \delta \ell(S)$, contradicting the choice of the segment S , finishing the proof. \square

5.4. Two-sided Lorenz attractor in $\tilde{\mathcal{O}}_\varphi^{+,+}$

PROPOSITION 5.3. For any $X \in \tilde{\mathcal{O}}_\varphi^{+,+}$, the maximal invariant set in U is transitive and consists of a two-sided Lorenz attractor.

Vector fields X in $\tilde{\mathcal{O}}_\varphi^{+,+}$ are characterized by the fact that the points q_1 and q_2 belong to different components Σ_+ (containing γ_+^s) and Σ_- (containing γ_-^s) of $\Sigma \setminus (W_1^s \cup W_2^s)$, where $W_i^s = W^s(p_i)$ and p_i is the fixed point of P in Σ^i . Thus, $\tilde{\mathcal{O}}_\varphi^{+,+}$ is the union of two disjoint open subsets, defined by $q_1 \in \Sigma_+$ or $q_1 \in \Sigma_-$. The proof of the proposition is symmetrical in these two open sets. We provide here the proof where $q_1 \in \Sigma_+$. See Figure 17.

Proof. Most of the proof is identical to the proofs of Propositions 5.1 and 5.2, and allows us to consider a segment S so that any component in any iterate $P^n(S)$ has a length bounded by $\delta \ell(S)$ with $1 < \delta < \lambda/\varphi$, where λ is the expansion rate of X . Furthermore, S cuts exactly one of the stable leaves γ_+^s or γ_-^s . Let us assume that S cuts γ_-^s , and denote $S_i = S \cap \Sigma_i$. If one of $P(S_1)$ or $P(S_2)$ is disjoint from $\gamma_+^s \cup \gamma_-^s$, then one concludes in the same way as in the proof of Proposition 5.2 that, using Lemma 4.10, one of the iterates $P(S_1)$, $P^2(S_1)$, $P(S_2)$, or $P^2(S_2)$ contains a segment of length larger than λ/φ contradicting the choice of S . Thus, one may assume that both $P(S_1)$ and $P(S_2)$ cut $\gamma_+^s \cup \gamma_-^s$. For the orientation of \mathcal{C}^u , S_1 has its endpoint at γ_-^s . Thus, $P(S_1)$ ends at $q_1 \in \Sigma_+$. As seen above, $P(S_1)$ cuts $\gamma_+^s \cup \gamma_-^s$ and its orientation implies that indeed it cuts γ_-^s . In particular, it goes out of Σ_+ . One deduces that $P(S_1)$ cuts transversely $W_2^s = W^s(p_2)$, where p_2 is the fixed point in

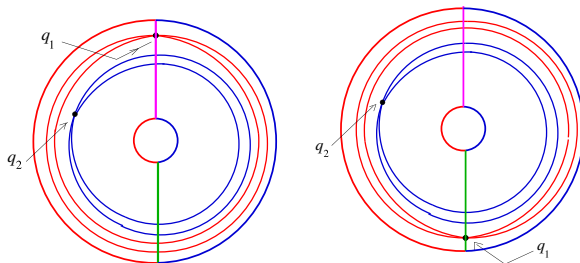

FIGURE 18. $X \in \mathcal{H}^1 \cup \mathcal{H}^2$.

Σ_2 (recall that $X \in \mathcal{O}_{\varphi}^{+,+}$). Thus, Lemma 4.9 ensures that the iterates of $P(S_2)$ cross all stable leaves but a finite number of them, concluding that case.

The case where S cuts γ_+^s is similar, just replacing $S_1 = S \cap \Sigma_1$ and $W^s(p_2)$ by $S_2 = S \cap \Sigma_2$ and $W^s(p_1)$. This concludes the proof. \square

5.5. Two-sided Lorenz attractor in hypersurfaces \mathcal{H}^i of homoclinic loops

THEOREM B. For any $X \in \mathcal{O}_1$ in one of the hypersurfaces \mathcal{H}^1 or \mathcal{H}^2 , the maximal invariant in U is a transitive singular attractor meeting both stable sets $W_{\pm}^s(\sigma)$.

Proof. We assume that one of the points q_1, q_2 , say q_1 , belongs to one of the stable leaves γ_+^s or γ_-^s , say $q_1 \in \gamma_+^s$ (all the cases admit an identical proof, *mutatis mutandis*). See Figure 18.

Similarly to the proof of Propositions 5.1, 5.2, and 5.3, the proof consists in considering an unstable segment S which does not admit any segment \tilde{S} of length larger than $\delta\ell(S)$, $1 < \delta < \lambda/\varphi$, so that \tilde{S} , excepted a finite subset, is contained in the union of the iterate $P^n(S)$, $n \geq 0$. One needs to prove that the iterates of such a segment S cut any stable leaves but a finite number of them. Again, the choice of S implies that S cuts γ_+^s or γ_-^s , and if it cuts both, then $P(S)$ already cuts all stable leaves but one. So we assume that S cuts only one of these leaves.

Assume first that S cuts γ_+^s . Consider $S_1 = S \cap \Sigma^1$. It is a segment starting at a point in γ_+^s and contained in Σ^1 . Then $P(S_1)$ is a segment a length larger than $\lambda\ell(S)$ and starting at $q_1 \in \gamma_+^s$. If $P(S_1)$ is not included in Σ^1 , then it cuts both γ_+^s and γ_-^s , and $P^2(S_1)$ cuts all leaves but one. If $P(S_1) \subset \Sigma^1$, then $P^2(S_1)$ is a segment of length larger than $\lambda^2\ell(S)$ and starting at q_1 . Iterating the process, one gets that one of the iterates $P^k(S_1)$ crosses completely Σ^1 so that $P^{k+1}(S_1)$ cuts all stable leaves but one, and we are done.

Assume now that S cuts γ_-^s . Consider $S_i = S \cap \Sigma^i$. Then $P(S_1)$ is a segment ending at $q_1 \in \gamma_+^s$, and $P(S_1)$ either crosses completely Σ^2 (and we are done) or is contained in Σ^2 . Now $P^2(S_1)$ is a segment ending at q_2 . However, $P(S_2)$ is a segment starting at q_2 . Now $P^2(S_1) \cup \{q_2\} \cup P(S_2)$ is a segment of length at least $\lambda\ell(S)$. This contradicts the choice of S , ending the proof. \square

The statement of Theorem B does not announce a two-sided Lorenz attractor, because the \mathcal{H}^i are not open subsets, and then the robustness of the transitivity is not ensured.

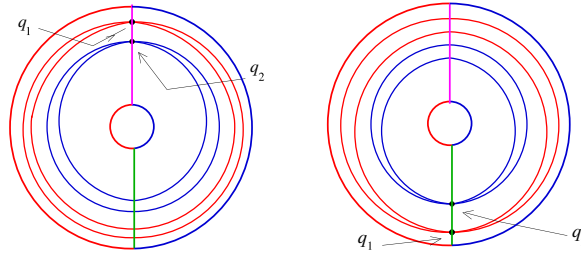

FIGURE 19. $X \in \mathcal{H}^1 \cup \mathcal{H}^2$, and $q_1, q_2 \in \gamma_+^s$ and $q_1, q_2 \in \gamma_-^s$.

However, we will see below that $X \in \mathcal{H}^i$ exhibits indeed a two-sided Lorenz attractor excepted for X in a codimension 2 submanifold. Let $\mathcal{H}_+^{1,2}$ and $\mathcal{H}_-^{1,2}$ be the codimension 2 submanifolds included in $\mathcal{H}^1 \cup \mathcal{H}^2$ consisting in vector fields X so that $q_1, q_2 \in \gamma_+^s$ or $q_1, q_2 \in \gamma_-^s$, respectively, see Figure 19. Thus, both unstable separatrices of σ are homoclinic connections and are included in the same connected component of $W^s(\sigma) \setminus W^{ss}(\sigma)$.

The next lemma ensures that for $X \in \mathcal{H}^i$ out of $\mathcal{H}_+^{1,2}$ and $\mathcal{H}_-^{1,2}$, the transitivity of the attractor is robust so that the attractor is a two-sided Lorenz attractor.

THEOREM C. *If $X \in \mathcal{H}^i \setminus (\mathcal{H}_+^{1,2} \cup \mathcal{H}_-^{1,2})$, there is a neighborhood $\mathcal{U}(X)$ of X such that the maximal invariant set for every $Y \in \mathcal{U}(X)$ is a two-sided Lorenz attractor.*

Proof. The proof consists of unfolding the homoclinic loops and checking that all the possibilities lead to one of the $\mathcal{O}_\varphi^{-,-} \cup \mathcal{O}_\varphi^{+,-} \cup \mathcal{O}_\varphi^{-,+} \cup \widetilde{\mathcal{O}_\varphi^{+,+}} \cup \mathcal{H}^1 \cup \mathcal{H}^2$. \square

5.6. Two-sided Lorenz attractor in $\mathcal{L}^{+,-}$. Note that Propositions 5.1, 5.2, 5.3, and B and Lemma C together prove the following theorem.

THEOREM D. *For any $X \in \mathcal{L}^{+,-}$, the maximal invariant set in U is a transitive singular hyperbolic attractor meeting both stable sets $W_-^s(\sigma)$ and $W_+^s(\sigma)$; that is, it is a two-sided Lorenz attractor.*

The region $\mathcal{L}^{+,-}$ has been defined as a union of many regions, and the propositions listed above prove the conclusion of Proposition D in each of these regions. Finally, some of these regions are not open, so Lemma C checks that the vector fields in these non-open regions admit neighborhoods contained in the union of the other regions.

5.7. The collisions of the Lorenz attractor and a fake horseshoe: vector fields in \mathcal{HE}_i . In this section, we consider vector fields X in $\mathcal{O}_\varphi^{+,+}$, that is, so that the return map P has two fixed points $p_i \in \Sigma^i$, $i = 1, 2$, a heteroclinic connection between σ and one of the points p_i . More precisely, q_i belongs to the stable leaf W_j^s through p_j ; note that $j \neq i$ because q_i is not in Σ^i when Σ^i contains a fixed point. The case when both q_1 and q_2 belong to $W_1^s \cup W_2^s$ corresponds to $X \in \mathcal{HE}_1 \cap \mathcal{HE}_2$, which is a codimension 2 submanifold.

THEOREM E. *For any $X \in \mathcal{HE}_1 \cap \mathcal{HE}_2$, there is a unique chain recurrence class, which is not transitive. Both Σ_- and Σ_+ are invariant by P . The maximal invariant set of the*

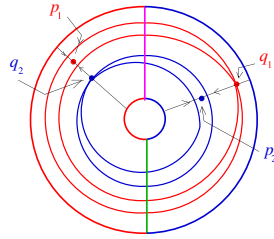

FIGURE 20. $X \in \mathcal{HE}_1 \cap \mathcal{HE}_2$.

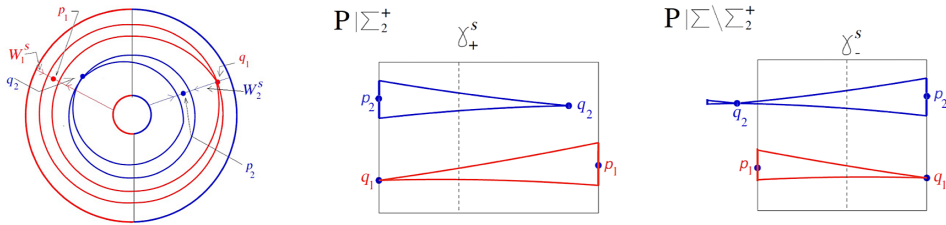

FIGURE 21. The left diagram displays $P(\Sigma)$ for $X \in \mathcal{HE}_1 \setminus (\mathcal{HE}_1 \cap \mathcal{HE}_2)$ and $q_2 \in \Sigma_2^+$. The middle diagram displays the restriction of $P|_{\Sigma_2^+}$ and the right diagram displays the restriction of P to $\Sigma \setminus \Sigma_2^+$.

restriction of P to Σ_i is transitive: every unstable segment in Σ_i has its iterates which cut every segment in Σ_i . The attracting set U splits into 2 connected compact sets, each containing a full Lorenz intersecting along $W^s(p_1) \cup W^s(p_2) \cup W^u(\sigma)$.

Proof. The first return map is illustrated in Figure 20. The study of the first return map in each rectangle $\bar{\Sigma}_i$ is classical for the expansion rate larger than $\sqrt{2} < \varphi$. □

The submanifold $\mathcal{HE}_1 \cap \mathcal{HE}_2$ cuts \mathcal{HE}_1 into two (relative) open subsets, as q_2 belongs either to Σ_+ or Σ_- (connected components of $\Sigma \setminus (W_1^s \cup W_2^s)$). In the same way, the submanifold $\mathcal{HE}_2 \cap \mathcal{HE}_2$ cuts \mathcal{HE}_2 into two (relative) open subsets, as q_1 belongs either to Σ_+ or Σ_- (connected components of $\Sigma \setminus (W_1^s \cup W_2^s)$).

We will consider $X \in \mathcal{HE}_1 \setminus (\mathcal{HE}_1 \cap \mathcal{HE}_2)$, and $q_2 \in \Sigma_+$, the other cases are similar.

Then the stable leaf through q_2 cuts Σ_+ into two components, one, denoted as Σ_1^+ , bounded by the stable leaf W_1^s through p_1 and the other, denoted as Σ_2^+ , bounded by W_2^s (which contains q_1 by definition of \mathcal{HE}_1); notice that Σ_2^+ contains the stable leaf γ_+^s , because $q_2 \in \Sigma^1$. Note that if $X \in \mathcal{HE}_1 \setminus (\mathcal{HE}_1 \cap \mathcal{HE}_2)$, then $q_1 \in W^s(p_2)$ and $q_2 \notin W^s(p_1)$.

PROPOSITION 5.4. Consider $X \in \mathcal{HE}_1 \setminus (\mathcal{HE}_1 \cap \mathcal{HE}_2)$, and assume $q_2 \in \Sigma_+$. Then we have the following.

- X has a unique chain recurrence class in U , but this class is not transitive and consists of two (singular) homoclinic classes K_-, K_+ containing σ .
- The iterates by P of any unstable segment in Σ cut any stable leaf in Σ_2^+ but finitely many of them. Furthermore, the return map P restricted to the rectangle Σ_2^+ is a Lorenz map for the parameter corresponding to one homoclinic connection. See Figure 21.

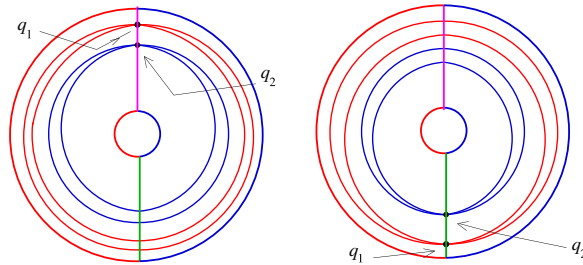

FIGURE 22. The maximal invariant set in U of $X \in \mathcal{H}_+^{1,2} \cup \mathcal{H}_-^{1,2}$ is a fat Lorenz.

- The homoclinic class K_- is a singular fake horseshoe that intersects Σ_- and is disjoint from Σ_+ .
- The intersection $K_- \cap K_+ \cap \Sigma$ is contained in W_2^s and consists of p_2 and the orbit of q_1 .

Proof. We refer the reader to the pictures illustrating the restriction of the return map P to Σ_2^+ and to $\Sigma \setminus \Sigma_2^+$. See Figure 21. \square

A similar result holds for $X \in \mathcal{HE}_i \setminus (\mathcal{HE}_1 \cap \mathcal{HE}_2)$ and $q_i \in \Sigma_j$, $i \in \{1, 2\}$ and $j \in \{-, +\}$.

5.8. *Fat Lorenz attractor: vector fields in $\mathcal{H}_+^{1,2}$ and $\mathcal{H}_-^{1,2}$.* We start this section setting the concept of ‘fat Lorenz attractor’.

Definition 5.5. Consider a vector field $X \in \mathcal{O}_\varphi$ and Λ its maximal invariant (compact) set in U . We say that Λ is a *fat Lorenz attractor* if every unstable segment in $\Sigma \setminus \gamma_+^s$ (respectively $\Sigma \setminus \gamma_-^s$) has an iterate by P which cuts every stable leaf excepted γ_+^s (respectively γ_-^s), see Figure 22.

Notice that Definition 5.5 implies that Λ is a transitive attractor.

PROPOSITION 5.6. *If $X \in \mathcal{H}_+^{1,2}$ (respectively $X \in \mathcal{H}_-^{1,2}$), then the maximal invariant set in U is a fat Lorenz attractor.*

Proof. We just refer the reader to the pictures illustrating the return map P , Figures 18 and 22. \square

6. Collisions and collapses

This section describes the drastic changes of behavior appearing in the topological dynamics when a family X_μ crosses the boundary of the regions we described in §5.

6.1. *Collisions.* Let us consider a 1-parameter family $X_\mu \in \mathcal{O}_\varphi^{+,+}$, $\mu \in [-1, 1]$ with the following properties.

- The family crosses the hypersurface transversely \mathcal{HE}_+^1 at $\mu = 0$: this means that X_0 exhibits a heteroclinic connection $q_1 \in W_2^s$ and $q_2 \in \Sigma_+$.

- For $\mu < 0$, the vector field X_μ belongs to \mathcal{L}^+ : it has an up Lorenz attractor and Σ_- contains a fake horseshoe for P .
- For $\mu > 0$, the vector field X_μ has a two-sided Lorenz attractor.

In other words, X_μ consists of a generic unfolding of the heteroclinic connection $q_1 \in W_2^s$. The cuspidal point $q_{1,\mu}$ is moving with the parameter μ and is crossing transversely $W_{2,\mu}^s$ (stable leaf through $p_{2,\mu}$) for $\mu = 0$. For $\mu < 0$, the upper-Lorenz attractor is intersecting exactly every stable leaf in Σ^+ between $q_{2,\mu}$ and $q_{1,\mu}$, and the horseshoe in Σ_- is bounded by the stable leaves $W_{1,\mu}^s$, $W_{2,\mu}^s$ and contains the periodic points $p_{1,\mu}$ $p_{2,\mu}$.

When μ tends to 0, the point $q_{1,\mu}$ tends to a point $q_{1,0}$ in W_2^s , and this point $q_{1,0}$ is also the limit of the intersection of W_2^s with one of the rectangles (the one containing p_1) of the Markov partition of the fake horseshoe. This corresponds to a Cantor set in W_2^s of points of the fake horseshoe for X_μ , $\mu < 0$ whose diameter tends to 0 as $\mu \rightarrow 0$: all the Cantor set tends to $q_{1,0}$.

For the parameter 0, the Lorenz attractor no longer admits an attracting neighborhood and is no longer robust. The fake horseshoe becomes singular, and intersects the Lorenz attractor along σ and the orbits of $p_{2,0}$ and of $q_{1,0}$. When $\mu > 0$, the Lorenz attractor and the (singular) fake horseshoe merge into a two-sided Lorenz attractor.

Notice that if all the vector fields X_μ are assumed to be of class C^2 , then all along the parameter, X_μ admits a unique Sinai–Ruelle–Bowen measure ν_μ (see [11]). For $\mu \leq 0$, the support of ν_μ is the Lorenz attractor, and in particular, does not intersect Σ_- . For $\mu > 0$, the support of ν_μ intersects any stable leaf in Σ . Thus, the support of ν_μ changes drastically at the collision point.

Question 1. Is the map $\mu \mapsto \nu_\mu$ continuous (for the weak topology) at $\mu = 0$?

6.2. *The collapse of the horseshoe: parameter families crossing $\mathcal{H}_+^{1,2}$ or $\mathcal{H}_-^{1,2}$.* Recall that $\mathcal{H}_+^{1,2}$ is the codimension 2 submanifold corresponding to the double homoclinic connection $q_1, q_2 \in \gamma_+^s$. We consider here a 2-parameter family X_μ , $\mu = (\mu_1, \mu_2) \in [-1, 1]^2$ which is a generic unfolding of this double homoclinic connection: in other words, the family cuts transversely $\mathcal{H}_+^{1,2}$ at $\mu = (0, 0)$. We assume furthermore that, for any fixed μ_2 , the 1-parameter family X_{μ_1, μ_2} is transverse to \mathcal{H}^1 at $\mu_1 = 0$ and, reciprocally, for any fixed μ_1 , the 1-parameter family X_{μ_1, μ_2} is transverse to \mathcal{H}^1 at $\mu_2 = 0$. More precisely, one may assume that $X_{\mu_1, \mu_2} \in \mathcal{O}_\varphi^{\omega_1, \omega_2}$, where $\omega_i \in \{-, +\}$ is the sign of μ_i . When one unfolds this double homoclinic connection, if $q_{1,\mu}$ enters in Σ_2 (that is, $\mu_1 > 0$), then a fixed point $p_{1,\mu} \in \Sigma_1$ is created and tends to $q_{1,0} \in \gamma_+^s$ as μ tends to 0. In the same way, if $\mu_2 > 0$, then q_2 enters in Σ_1 and the fixed point $p_{2,\mu}$ is created in Σ_2 and tends to $q_{2,0} \in \gamma_+^s$. The stable leaves $W_{1,\mu}^s$ and $W_{2,\mu}^s$ bound the small strip Σ^+ in Σ containing γ_+^s (tending to the segment γ_+^s as $\mu \rightarrow 0$) and a large strip Σ^- . The vector field X_μ in $\mathcal{O}_\varphi^{+,+}$ belongs to $\mathcal{L}^+ \cup \mathcal{L}^-$ if and only if both q_1 and q_2 belong to the same component Σ^+ or Σ^- .

LEMMA 6.1. *For small μ , $\{q_1, q_2\}$ is not contained in Σ^+ . In other words, the closure of \mathcal{L}^+ is disjoint from $\mathcal{H}_+^{1,2}$. Here, $\{\mu \mid \{q_{1,\mu}, q_{2,\mu}\} \subset \Sigma_-\}$ is an open subset containing $(0, 0)$ in its closure. More precisely, for any $\alpha > 0$, there is μ_0 so that for any $0 < \mu < \mu_0$, the vector field $X_{\mu, \alpha\mu} \in \mathcal{L}^-$.*

Proof. Assume (arguing by contradiction) that $\{q_1, q_2\} \subset \Sigma^+$. Thus, $X \in \mathcal{L}^+$. Then Σ^+ is invariant under the action of P . However, as Σ^+ is contained in an arbitrarily small neighborhood of γ_+^s , the rate of expansion of P in the unstable cone is arbitrarily large, in particular, $\gg 2$. So Σ^+ cannot be invariant, ending the proof.

The proof of the second point is as follows: consider one half-line $X_{\mu, \alpha\mu}$ and consider $\mu > 0$ very small. Thus, the point q_1 (respectively q_2) belongs to Σ_2 (respectively Σ_1) and its distance to γ_+^s is μ (respectively $\alpha\mu$). Consider any point p in Σ_1 at a small distance $> \frac{1}{2}\alpha\mu$ from γ_+^s . Consider an unstable segment γ_p realizing this distance so that γ_p starts at γ_+^s and ends at p . Then $P(\gamma_p)$ is an unstable segment starting at q_1 and ending at $P(p)$. The length $\ell(P(\gamma_p))$ is arbitrarily larger than $\ell(\gamma_p)$ (say, larger than $100(1 + \alpha)\mu\ell(\gamma_p)$) as μ tends to 0 (as the expansion rate close to γ_+^s tends to infinity).

One deduces that the point $P(p)$ belongs to Σ_1 and is at a distance larger than $99(1 + \alpha)\mu$ of γ_+^s . One deduces that $P(p)$ (and thus p) does not belong to the stable leaf through the fixed point $p_1 \in \Sigma_1$. In particular, q_2 belongs to Σ_- . One proves in the same way as for $\mu > 0$ small $q_1 \in \Sigma_-$, and thus the vector field belongs to \mathcal{L}^- , ending the proof. Figure 4 displays a local bifurcation diagram in this case. \square

The lemma implies that when one considers a segment in the parameter plane crossing $(0, 0)$ and entering in $\mathcal{O}_\varphi^{+,+}$ transversely to both \mathcal{H}^1 and \mathcal{H}^2 , then one creates a down-Lorenz attractor, which cuts every stable leaf in Σ^- . When the parameter tends to $(0, 0)$, then Σ^- tends to Σ and the Lorenz attractor tends to what we call the fat Lorenz attractor. The horseshoe, corresponding to Σ^+ , collapses into the double homoclinic connection.

6.3. *Switching from upper to down: family crossing $\mathcal{HE}_1 \cap \mathcal{HE}_2$.* In this section, we consider a two-parameter family $X_\mu \in \mathcal{O}_\varphi^{+,+}$, $\mu = (\mu_1, \mu_2)$ crossing transversely $\mathcal{HE}_1 \cap \mathcal{HE}_2$ at $\mu = 0$. In other words, $X_{(0,0)}$ exhibits two heteroclinic connections $q_1 \in W_2^s$ and $q_2 \in W_1^s$ (recall that W_i^s is the stable leaf through the fixed point p_i). We have seen that this behavior implies that $X_{(0,0)}$ has two *full Lorenz* which intersect along $W^s(p_1) \cup W^s(p_2) \cup W^u(\sigma)$. See Figure 20. Up to reparameterization, the family one may assume that

$$\begin{aligned} (\mu_1 = 0 \Leftrightarrow q_1 \in W_2^s) \quad \text{and} \quad (\mu_2 = 0 \Leftrightarrow q_2 \in W_1^s), \\ (\mu_1 > 0 \Leftrightarrow q_1 \in \Sigma^+) \quad \text{and} \quad (\mu_2 > 0 \Leftrightarrow q_2 \in \Sigma^+). \end{aligned}$$

With these notation, note that Theorems F and G are a reformulation of the results in the previous sections. Figure 23 displays the local bifurcations.

7. Parameter families $X_\mu \in \mathcal{O}_\varphi$, with parameters in the torus

7.1. \mathbb{T}^2 -parameter families

Definition 7.1. Let $\pi: \mathbb{R}^2 \rightarrow \mathbb{T}^2 = \mathbb{R}^2/\mathbb{Z}^2$ be the canonical projection. Let $V \subset \mathbb{R}^2$ be an open subset so that the projection $\pi(V)$ is the whole torus \mathbb{T}^2 . We say that a family $\{X_\mu \in \mathcal{O}_1\}_{\mu \in V}$ is a C^r , $r \geq 0$, family of vector fields in \mathcal{O}_1 parameterized by \mathbb{T}^2 if:

- the map $\mu \rightarrow X_\mu$ is continuous for the C^1 -topology;
- the map $(p, \mu) \mapsto X_\mu(p)$ is of class C^r ;

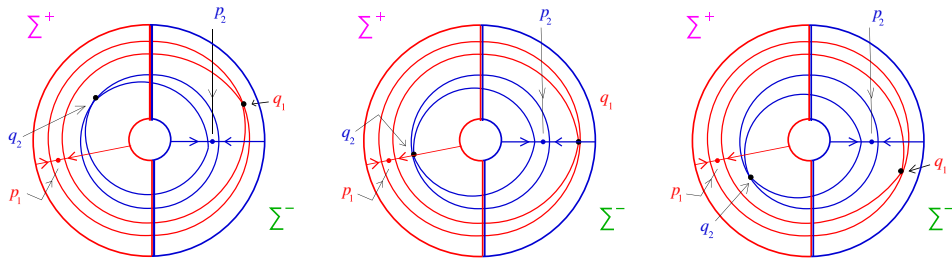

FIGURE 23. Local bifurcation: (a) $(\mu_1, \mu_2), \mu_i > 0$; (b) $(\mu_1, \mu_2), \mu_i = 0$; (c) $(\mu_1, \mu_2), \mu_i < 0$.

- for any μ, μ' so that $\mu' - \mu \in \mathbb{Z}^2$ one has: the return maps P, P' of X, X' on the transverse cross-section Σ coincide: $P = P'$. In particular, the restriction of X and X' to the attracting region U are smoothly topologically equivalent, by an equivalence whose restriction to the cross-section Σ is the identity map.

Shortly, we say that X_μ is a \mathbb{T}^2 -parameter family.

7.2. Essential families. This section aims to define the notion of essential \mathbb{T}^2 families. Roughly, we do not want the family X_μ to be contained in a small neighborhood of a given vector field X_0 . We want that, when μ follows a simple closed path in \mathbb{T}^2 , non-homotopic to a point, then the images $P(\Sigma^1)$ or $P(\Sigma^2)$ give a turn in Σ in an essential way.

Let us first present a non-intrinsic definition of these phenomena. Afterwards, we will see an intrinsic definition, showing that the definition does not depend on the choices. Consider a \mathbb{T}^2 -parameter family $\{X_\mu\}$, and let $\gamma_{+,\mu}^s$ and $\gamma_{-,\mu}^s$ be the associated stable leaves corresponding to the discontinuities of the first return map. The leaves $\gamma_{+,\mu}^s$ vary continuously with μ . This allows us to choose a parameterization of Σ , depending on μ , and so that $\gamma_{+,\mu}^s$ is the segment $\{0\} \times [-1, 1]$ in the annulus $\Sigma = \mathbb{R}/\mathbb{Z} \times [-1, 1]$.

Consider now the points $q_{1,\mu}$ and $q_{2,\mu}$ (first intersection points of the unstable separatrices of σ_μ with Σ). This defines two continuous maps $q_1: \mathbb{T}^2 \rightarrow \mathbb{R}/\mathbb{Z} \times [-1, 1]$ and $q_2: \mathbb{T}^2 \rightarrow \mathbb{R}/\mathbb{Z} \times [-1, 1]$. Then, composing q_1 and q_2 by the projection $\psi: \mathbb{S}^1 \times [-1, 1] \rightarrow \mathbb{S}^1$, one gets two continuous maps $\psi \circ q_i: \mathbb{T}^2 \rightarrow \mathbb{S}^1, i = 1, 2$. Let us denote $Q = (\psi \circ q_1, \psi \circ q_2): \mathbb{T}^2 \rightarrow \mathbb{T}^2$.

Definition 7.2. With the notation above, we say that the family X_μ is essential if the topological degree of Q is 1 (or else, if Q is homotopic to an orientation preserving homeomorphism).

In Definition 7.2, the homotopy class of Q depends on the parameterization of Σ that we choose. Let us convince you that the topological degree of Q does not depend on the choice of parameterization of Σ .

Consider the hypersurface $\Gamma_+^s \subset \Sigma \times \mathbb{T}^2$ defined by $\Gamma_+^s = \bigcup_\mu \gamma_{+,\mu}^s \times \{\mu\}$. In the parameterization above, it is $\{0\} \times [-1, 1] \times \mathbb{T}^2 \subset \Sigma \times \mathbb{T}^2$. Thus, it is a compact 3-manifold with a boundary homeomorphic to $[-1, 1] \times \mathbb{T}^2$, whose boundary is contained

in the boundary of $\Sigma \times \mathbb{T}^2$. As a consequence, the algebraic intersection number of a closed curve in $\Sigma \times \mathbb{T}^2$ with Γ_+^s is well defined.

To every closed path $c: \mathbb{S}^1 \rightarrow \mathbb{T}^2$, let us consider the closed paths $q_{i,c}: \mathbb{S}^1 \rightarrow \Sigma \times \mathbb{T}^2$, $i \in \{1, 2\}$ so that $q_{i,c}(\theta) = (q_{i,c}(\theta), c(\theta))$ for $\theta \in \mathbb{S}^1$.

Notice that $q_{i,c}$ depends continuously on the closed path c . In particular, its algebraic intersection number with the hypersurface Γ_+^s only depends on the homology class $[c]$. We denote it by $[q_{i,c}] \cdot \Gamma_+^s$. One gets a map

$$[c] \mapsto ([q_{1,c}] \cdot \Gamma_+^s, [q_{2,c}] \cdot \Gamma_+^s) \in \mathbb{Z}^2$$

defined on $H_1(\mathbb{T}^2, \mathbb{Z}) \simeq \mathbb{Z}^2$ with values in \mathbb{Z}^2 , and this map is a linear map given by a 2 by 2 matrix with \mathbb{Z} -entries. The topological degree of Q is the determinant of this linear map: the family is essential if and only if the determinant is 1, which does not depend on the parameterization choice.

7.3. Building \mathbb{T}^2 -families. Consider a vector field $X \in \mathcal{O}_1$ on \mathbb{R}^3 . Thus, by definition, it is transversal to the annuli Σ , D_1 , and D^2 . Furthermore, the first return map $R: D_1 \cup D_2 \rightarrow \Sigma$ is smooth and maps D_1 and D_2 on two disjoint essential annuli in the interior of Σ .

Consider an annuli \tilde{D}_i , $i = 1, 2$, containing D_i in its interior, and so that R extends in a diffeomorphism $\tilde{R}: \tilde{D}_1 \cup \tilde{D}_2 \rightarrow \Sigma$, which is the first return map from \tilde{D}_i to $\Sigma \cup \tilde{D}_1 \cup \tilde{D}_2$. We denote by Δ_i the union of the X -orbit segment joining points $p \in \tilde{D}_i$ to $\tilde{R}(p)$. Thus, (Δ_i, X) is smoothly orbitally equivalent to $(\tilde{D}_i \times [0, 1], \partial/\partial t)$. The next lemma expresses that one can realize by a continuous family of vector fields in \mathbb{R}^3 any continuous deformation of the return map R .

LEMMA 7.3. *Consider a continuous family $R_\mu: D_1 \cup D_2 \rightarrow \tilde{R}(\tilde{D}_1 \cup \tilde{D}_2)$, $\mu \in V$, where $V \subset \mathbb{R}^2$ is an open disk containing 0. One assumes $R_0 = R$. Then there is a family of vector fields X_μ with the following properties:*

- $X_0 = X$;
- for any μ , X_μ satisfies all the topological properties (items (1) to (7)) of the definition of the set \mathcal{O}_1 ;
- for any μ , X_μ coincides with X out of $\Delta_1 \cup \Delta_2$;
- for any μ , the restriction of X_μ to Δ_i is transverse to the fibers $\tilde{D}_i \times \{t\}$;
- the return map of X from $D_1 \cup D_2$ to Σ is R_μ .

Proof. One extends R_μ to \tilde{D}_i in a diffeomorphism \tilde{R}_μ so that all \tilde{R}_μ coincide with \tilde{R} in a neighborhood of the boundary $\partial\tilde{D}_i$. Then we replace the restriction of X in Δ_i with a vector field that coincides with X in a neighborhood of $\partial\Delta_i$ and where the entrance exit map is \tilde{R}_μ . \square

Assume now that the projection of V on $\mathbb{R}^2/\mathbb{T}^2$ covers the whole torus \mathbb{T}^2 , and assume that the family R_μ is \mathbb{Z}^2 -periodic in the following sense:

- for any $\mu_1, \mu_2 \in V$ so that $\mu_2 - \mu_1 \in \mathbb{Z}^2$, then $R_{\mu_1} = R_{\mu_2}$.

Then the family X_μ defined in Lemma 7.3 is a \mathbb{T}^2 -parameter family of vector fields having U as an attracting region.

7.4. An essential \mathbb{T}^2 -family of vector fields in \mathcal{O}_φ . Consider $\Sigma \simeq \mathbb{S}^1 \times [-1, 1]$ with the coordinates θ, t and consider the constant cone field \mathcal{C} defined by

$$\mathcal{C}(p) = \left\{ u = \alpha \frac{\partial}{\partial \theta} + \beta \frac{\partial}{\partial t} \in T_p \Sigma \text{ so that } |\alpha| \geq |\beta| \right\}.$$

We denote by $\mathcal{R}_\alpha: \Sigma \rightarrow \Sigma$ the rotation of angle $\alpha \in \mathbb{S}^1$, that is, $(\theta, t) \mapsto (\theta + \alpha, t)$. Recall that $R: D_1 \cup D_2 \rightarrow \Sigma$ is the first return map of D_i to $\Sigma \cup D_1 \cup D_2$.

Consider a vector field $X \in \mathcal{O}_\varphi$ with the following extra properties.

- The constant cone field \mathcal{C} is the unstable cone field \mathcal{C}^u .
- The images $R(D_i)$ are product annulus $\mathbb{S}^1 \times I_i \subset \Sigma = \mathbb{S}^1 \times [-1, 1]$.

Now consider the \mathbb{Z}^2 -family of maps $R_{\alpha,\beta}: D_1 \cup D_2 \rightarrow \Sigma$, $\alpha, \beta \in \mathbb{T}^2 = \mathbb{R}^2/\mathbb{S}^2$ defined by

$$R = \mathcal{R}_\alpha \circ R \text{ on } D_1 \quad \text{and} \quad R = \mathcal{R}_\beta \circ R \text{ on } D_2.$$

According to Lemma 7.3, one can realize the periodic family R_μ by a \mathbb{T}^2 -parameter family of vector fields X_μ , and one can easily check.

LEMMA 7.4. The family X_μ is a \mathbb{T}^2 -parameter essential family in \mathcal{O}_φ .

8. Reduction to one-dimensional dynamics

8.1. The action of the return map on the space of stable leaves. Any C^1 vector field $X \in \mathcal{O}_1$ is singular hyperbolic in the attracting region U , with a continuous strong stable direction. There is a well-defined *stable foliation* (also called *strong stable foliation*) tangent to the stable distribution with leaves having the same regularity as X . It admits, therefore, a well-defined two-dimensional (*weak*)*stable foliation* (also called *center-stable foliation*) out of the strong stable manifold of the singularity. The leaves of the weak stable foliation are the orbits for the flow of the leaves of the strong stable one: out of the strong stable manifold of σ , the vector is not tangent to the stable direction, so these orbits are two-dimensional. Along the strong stable manifold of σ , the vector field is tangent to the one-dimensional strong stable leaf, so the foliation is singular. The strong stable foliation is not tangent to Σ . However, the two-dimensional center-stable foliation cuts the annulus Σ transversely along a one-dimensional foliation \mathcal{F}^s , which is the stable foliation of the return map P . The segments γ_+^s and γ_-^s are leaves of \mathcal{F}^s .

The foliation \mathcal{F}^s is transverse to the unstable cone field \mathcal{C}^u . The leaves of the foliation \mathcal{F}^s are segments crossing Σ (connecting the two boundary components of Σ). The leaves space Σ/\mathcal{F}^s is a (topological) circle \mathbb{S}_X^1 . The leaves γ_+^s and γ_-^s each induce a point c_+ and c_- , respectively, on \mathbb{S}_X^1 . Note that the flow X^t preserves the center-stable foliation, and thus the first return map P preserves the foliation \mathcal{F}^s . As a consequence, P passes to the quotient as a map $f = f_X$ defined from $\mathbb{S}_X^1 \setminus \{c_+, c_-\}$ to \mathbb{S}_X^1 . As $P(\Sigma^i)$ is an essential pinched annulus in Σ , we deduce that f_X restricted to each interval of $\mathbb{S}_X^1 \setminus \{c_+, c_-\}$ is a diffeomorphism on a punctured circle.

8.2. *Increasing the regularity of the foliation.* In a recent work [7], Araújo and Melbourne adapt to our setting a condition from [27], ensuring the smoothness of the strong stable foliation of X :

- there exists $t > 0$ such that

$$\|DX^t|_{E_x^s}\| \cdot \|DX^{-t}|_{E_{X^t(x)}^{cu}}\| \cdot \|DX^t|_{E_x^{cu}}\| < 1 \quad \text{for all } x \in \Lambda. \quad (3)$$

As a consequence of Theorem 2.8, the weak stable foliation of X and the stable foliation F^s of the first return map P are of class C^1 . Therefore, the circle \mathbb{S}_X^1 is endowed with a natural C^1 -structure, and f_X is of class C^1 .

9. Symbolic dynamics and topological classification

As for the classical geometric model of Lorenz attractor, we will see in that section that, to any vector field in \mathcal{O}_1 , one can associate combinatorial data, called the itinerary of the discontinuities. Furthermore, these itineraries provide a topological classification of the vector fields in the attracting region U . We fix a vector field $X \in \mathcal{O}_1$ and its return map $P: \Sigma \rightarrow \Sigma$ in this section.

9.1. *Itineraries for the return map P on Σ .* Recall that Σ is endowed with two specific stable leaves γ_+^s and γ_-^s , which split Σ in Σ_1 and Σ_2 . Note that γ_+^s cuts both pinched annuli $P(\Sigma_i)$ along one stable leaf, except in the case where $q_i \in \gamma_+^s$. Thus, $P^{-1}(\gamma_+^s)$ cuts Σ_i into two components (one of them being empty if $q_i \in \gamma_+^s$):

- we denote by A_0 and A_1 the two components of $\Sigma_1 \setminus P^{-1}(\gamma_+^s)$, where A_0 starts at γ_+^s (for the positive orientation of the circle \mathbb{S}^1 of $\Sigma = \mathbb{S}^1 \times [-1, 1]$). If $q_1 \in \gamma_+^s$, then $A_1 = \emptyset$;
- we denote by B_0 and B_1 the two components of $\Sigma_2 \setminus P^{-1}(\gamma_+^s)$, where B_0 is starting at γ_-^s . If $q_1 \in \gamma_+^s$, then $B_1 = \emptyset$.

We consider $\mathbb{X} = \{A_0, A_1, B_0, B_1\}^{\mathbb{N}}$ as the space of infinite positive words in the alphabet $\{A_0, A_1, B_0, B_1\}$. A finite word of length k is an element $\{\omega_0, \dots, \omega_{k-1}\}$ of $\{A_0, A_1, B_0, B_1\}^k$.

Given $\omega = \{\omega_i\}_{i \in \mathbb{N}} \in \mathbb{X}$, we denote by $[\omega]_k$ the initial word $\{\omega_0, \dots, \omega_{k-1}\}$ of length k of ω .

Remark 9.1. For any $k > 0$ and any $\varepsilon \in +, -$, $P^{-k}(\gamma_\varepsilon^s)$ consists in at most 2^k stable leaves.

Definition 9.2. For every $p \in \Sigma \setminus \bigcup_{j=0}^k P^{-j}(\gamma_+^s \cup \gamma_-^s)$, we denote by $[\omega(p)]_k = \{\omega_0(p), \dots, \omega_{k-1}(p)\}$ the word defined by $f^i(p) \in \omega_i(p)$ (recall that $\omega_i(p)$ is one of the four regions A_0, A_1, B_0, B_1). Here, $[\omega(p)]_k$ is called the k -itinerary of p .

Figure 24 displays the choice of the alphabet above for the one-dimensional dynamics as in the picture.

LEMMA 9.3. *Consider any point $p \in \Sigma$, and $S: [-1, 1] \rightarrow \Sigma$ a positively oriented unstable segment centered at p (that is, $S(0) = p$). Then for any $k \geq 0$, the itinerary $[\omega(S(t))]_k$ is well defined and constant for $t > 0$ (respectively $t < 0$) small enough. This itinerary is independent of the choice of S . We denote them by $[\omega_-(p)]_k$ and $[\omega_+(p)]_k$. If*

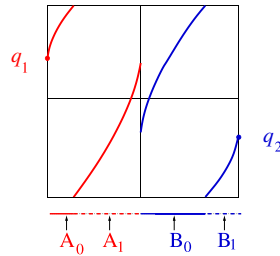

FIGURE 24. The chosen alphabet.

p_1 and p_2 belong to the same stable leaf, then $[\omega_{\pm}(p_1)]_k = [\omega_{\pm}(p_2)]_k$. In other words, the itinerary depends only on the stable leaf and not on the point in the leaf.

For any $p \in \Sigma$, one denotes by $\omega_-(p)$ and $\omega_+(p)$ the infinite words whose first segments of length k are respectively $[\omega_-(p)]_k$ and $[\omega_+(p)]_k$. They are called the *down-* and *upper-itinerary* of p , respectively. The *itinerary* of p is the pair of sequences $\omega(p) = (\omega_-(p), \omega_+(p))$.

Remark 9.4. If $p \notin W^s(\sigma)$ (that is, $P^k(p) \notin \gamma_{\pm}^s$ for all $k > 0$), then $\omega_-(p) = \omega_+(p)$ and the segment of length k is k -itinerary $[\omega(p)]_k$ of p . This shows that our terminology and notation are consistent.

The following remark says that the itineraries ω_+ and ω_- induce, in some sense, a semi-conjugacy of (Σ, P) with $(\mathbb{X}, \mathfrak{S})$, where \mathfrak{S} is the shift on \mathbb{X} . Being rigorous, P is defined on $\Sigma \setminus (\gamma_+^s \cup \gamma_-^s)$, which is not invariant under P . Thus, ω_{\pm} is a conjugacy in the restriction of $\Sigma \setminus W^s(\sigma)$. As P is discontinuous along γ^s+ and γ^s- , we also explain the itinerary of these points. Recall the star map (denoted by \star) defined on \mathbb{X} as follows: given a sequence $w = (w_0, w_1, \dots) \in \mathbb{X}$ and a letter $L \in \{A_0, A_1, B_0, B_1\}$, $L \star w \stackrel{\text{def}}{=} (L, w_0, w_1, \dots)$.

Remark 9.5

- For any $x \in \Sigma \setminus (\gamma_+^s \cup \gamma_-^s)$ (that is, $P(x)$ is defined), then

$$\omega_-(P(x)) = \mathfrak{S}(\omega_-(x)) \quad \text{and} \quad \omega_+(P(x)) = \mathfrak{S}(\omega_+(x)).$$

- For $x \in \gamma_+^s$, one has $\omega_+(x) = A_0 \star \omega_+(q_1)$ and

$$\begin{aligned} \omega_-(x) &= B_1 \star \omega_-(q_2) \text{ if } q_2 \notin \gamma_+^s, \\ \omega_-(x) &= B_0 \dots B_0 \dots, \text{ if } q_2 \in \gamma_+^s \quad (\text{and then } B_1 = \emptyset). \end{aligned}$$

- For $x \in \gamma_-^s$, one has $\omega_+(x) = B_0 \star \omega_+(q_2)$ and

$$\begin{aligned} \omega_-(x) &= A_1 \star \omega_-(q_1) \text{ if } q_1 \notin \gamma_+^s, \\ \omega_-(x) &= A_0 \star \omega_-(q_1) \text{ if } q_1 \in \gamma_+^s \quad (\text{and then } A_1 = \emptyset). \end{aligned}$$

According to Lemma 9.3, the itineraries ω_- and ω_+ are functions of the stable leaf. So they pass to the quotient on the leaves space \mathbb{S}_X^1 . We still denote by ω_- and ω_+ the quotient maps $\omega_{\pm} : \mathbb{S}_X^1 \rightarrow \mathbb{X}$.

9.2. *Order and topology.* We endow the alphabet $\{A_0, A_1, B_0, B_1\}$ with the total order $A_0 < A_1 < B_0 < B_1 < 1$, which corresponds to the order in an unstable segment starting at γ_+^s and crosses the corresponding regions in Σ . We endow \mathbb{X} with the corresponding lexicographic order that we denote by $<$ (and \preceq for the non-strict order).

PROPOSITION 9.6. *Let $S: [0, 1] \rightarrow \Sigma$ be an unstable segment, positively oriented, whose interior is contained in $\Sigma \setminus \gamma_+^s$. Then:*

- for any $t \in (0, 1)$, one has $\omega_-(S(t)) \preceq \omega_+(S(t))$;
- for any $t_1, t_2 \in [0, 1]$ so that $t_1 < t_2$, one has $\omega_+(S(t_1)) < \omega_-(S(t_2))$.

This proposition has a straightforward translation for the itineraries associated with the one-dimensional dynamic f .

Proof. For the first item, we already have seen that if $S(t)$ does not belong to $W^s(\sigma)$, then $\omega_-(S(t)) = \omega_+(S(t))$, and there is nothing to prove.

Consider $t_1 < t_2$ so that $S(t_i) \notin W^s(\sigma)$. As ω_+ and ω_- coincide on $S(t_i)$, we just note $\omega^j = \omega_+(S(t_i)) = \omega_-(S(t_i))$. If the first letter is not the same, that is, $S(t_1)$ and $S(t_2)$ are not in the same region A_0, A_1, B_0, B_1 , then $(\omega^1)_0 < (\omega^2)_0$, by choice of the order on our alphabet, and so $\omega^1 < \omega^2$.

CLAIM 1. *Assume that $(\omega^1)_j = (\omega^2)_j$ for $j = 0, \dots, k-1$ but $(\omega^1)_k \neq (\omega^2)_k$.*

- P^j , $0 \leq j \leq k$ is defined on the unstable segment $S([t_1, t_2])$.
- $P^j(S([t_1, t_2]))$ is contained in one of the regions A_0, A_1, B_0, B_1 for $0 \leq j < k$.
- $P^k(S(t_1))$ and $P^k(S(t_2))$ are not in the same region.

Proof. The third item says $(\omega^1)_k \neq (\omega^2)_k$, which is our hypothesis. The proof of the two first items goes together and by induction. As $S(t_1)$ and $S(t_2)$ belong to the same region, and as the interior of S is disjoint from γ_+^s and S is an unstable segment (transverse to the fibration by stable leaves), this implies that $S([t_1, t_2])$ is contained in one of the regions of the alphabet. As $P^0 = \text{id}$ is clearly defined in $S([t_1, t_2])$, we proved both items for $j = 0$.

We assume now that both items have been proved for $0, \dots, j-1$ and let us prove them for j . Hence, $P^{j-1}(S([t_1, t_1]))$ is contained in one of the regions. Thus, P is well defined on this interval, meaning that P^j is well defined on $S([t_1, t_2])$, proving the first item.

If $j \neq k$, then $(\omega^1)_j = (\omega^2)_j$: in other words, the endpoints of the unstable segment $P^j(S([t_1, t_1]))$ belong to the same region. If the whole segment is contained in that region, we are done. Otherwise, $P^j(S([t_1, t_1]))$ crosses γ_+^s . This means that $P^{j-1}(S([t_1, t_1]))$ is crossing $P^{-1}(\gamma_+^s)$, and this (by definition of the regions A_0, A_1, B_0, B_1) contradicts the fact that $P^{j-1}(S([t_1, t_1]))$ is contained in one of these regions. This ends the proof of the claim. \square

CLAIM 2. *With the hypotheses above, $(\omega^1)_k < (\omega^2)_k$.*

Proof. According to Claim 1, the $P^{k-1}(S([t_1, t_1]))$ is an unstable segment contained in one of the regions, and we have seen in the proof that this implies that $P^k(S([t_1, t_1]))$

is an unstable segment that does not cross γ_+^s . As already seen, the choice of the order on A_0, A_1, B_0, B_1 implies that either $P^k(S([t_1, t_1]))$ is contained in one region (which contradicts $(\omega^1)_k \neq (\omega^2)_k$) or $(\omega^1)_k < (\omega^2)_k$, ending the proof of the claim. \square

The claims above show that for any $t_1 < t_2$ with $S(t_i) \notin W^s(\sigma)$, one has $\omega^1 \preceq \omega^2$.

CLAIM 3. Given $t_1 < t_2$ so that $S(t_i) \notin W^s(\sigma)$, then $\omega^1 \neq \omega^2$.

Proof. As in Claim 1, if $\omega^1 = \omega^2$, then P^j is well defined on $S([t_1, t_2])$ for any $j \geq 0$ and $P^j(S([t_1, t_2]))$ is contained in one of the regions A_0, A_1, B_0, B_1 . The length of these iterates increases exponentially, and these forbid (for large iterates) these segments to be contained in one region, ending the proof of the claim. \square

Consider now any $t_1 < t_2$. We need to prove $\omega_+^1 = \omega_+(S(t_1)) < \omega_-(S(t_2)) = \omega_-^2$. By definition of ω_- , there is a decreasing sequence $t_{1,n} < t_2$ tending to t_1 and so that:

- $S(t_{1,n}) \notin W^s(\sigma)$;
- $[\omega_+^1]_n = [\omega^{1,n}]_n$ (where $\omega^{1,n}$ is the itinerary of $S(t_{1,n})$).

Note that the sequence $\omega^{1,n}$ is strictly decreasing for $<$ and tends to ω_-^1 . In other words, $\omega_-^1 = \inf_{n \rightarrow +\infty} \omega^{1,n}$.

In the same way, we fix an increasing sequence $t_{2,n} > t_{1,0}$ tending to t_2 and so that:

- $S(t_{2,n}) \notin W^s(\sigma)$;
- $[\omega_-^2]_n = [\omega^{2,n}]_n$ (where $\omega^{2,n}$ is the itinerary of $S(t_{2,n})$).

Then $\omega_+^2 = \sup_{n \rightarrow +\infty} \omega^{2,n}$. As $\omega^{1,n} < \omega^{2,n}$, we conclude $\omega_+^1 < \omega_-^2$ by proving the second item of the proposition.

To end the proof, it remains to show that $\omega_-(S(t)) \preceq \omega_+(S(t))$ for any $t \in (0, 1)$. For that, we consider sequences $t_{-,n} < t_{-,n+1} < \dots < t < \dots < t_{+,n+1} < t_{+,n}$ tending to t as $n \rightarrow +\infty$ and so that:

- $S(t_{\pm,n}) \notin W^s(\sigma)$;
- $[\omega_-(S(t))]_n = [\omega^{-,n}]_n$ (where $\omega^{-,n}$ is the itinerary of $S(t_{-,n})$);
- $[\omega_+(S(t))]_n = [\omega^{+,n}]_n$ (where $\omega^{+,n}$ is the itinerary of $S(t_{+,n})$).

We know that $\omega^{-,n} < \omega^{+,n}$ (the itinerary is strictly increasing on the point out of $W^s(\sigma)$). So for every n , one has $[\omega_-(S(t))]_n \preceq [\omega_+(S(t))]_n$, ending the proof. \square

9.3. *Admissible itineraries.* Given $X \in \mathcal{O}_1$, we associate four itineraries: $\omega_+^\pm = \omega_+(\gamma_\pm^s)$, $\omega_-^\pm = \omega_-(\gamma_\pm^s)$, $\omega_+^- = \omega_+(\gamma_-^s)$, and $\omega_-^- = \omega_-(\gamma_-^s)$.

Definition 9.7. We say that an $\omega \in \mathbb{X}$ is admissible for the vector field X (or, shortly, X -admissible) if it satisfies the following inequalities.

- $\omega_+^\pm \preceq \mathfrak{S}^n(\omega) \preceq \omega_-^\pm$.
- If $(\omega)_i \in \{A_0, A_1\}$, then $\mathfrak{S}^i(\omega) \preceq \omega_-^-$.
- If $(\omega)_i \in \{B_0, B_1\}$, then $\omega_+^- \preceq \mathfrak{S}^i \omega$.

We denote by $\mathcal{A}_X \subset \mathbb{X}$ the set of X -admissible itineraries. Note that \mathcal{A}_X is a \mathfrak{S} -invariant compact set.

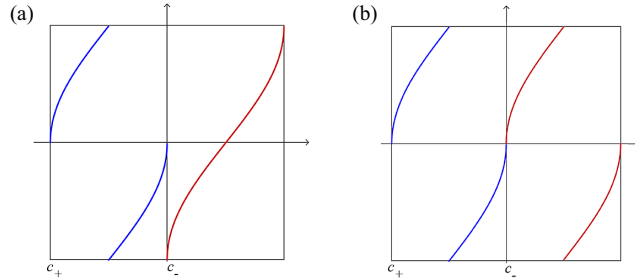

FIGURE 25. (a) $\mathcal{H}_-^1 \cap \mathcal{H}_+^2$, (b) $\mathcal{H}_-^1 \cap \mathcal{H}_-^2$.

We note that if X does not exhibit homoclinic loops, then $\lim_{x \rightarrow c_-^-} f_X^i(x) = \lim_{x \rightarrow c_+^+} f_X^i(x)$ and $\lim_{x \rightarrow c_+^+} f_X^i(x) = \lim_{x \rightarrow c_-^-} f_X^i(x)$ for all $i \in \mathbb{N}$, and therefore,

$$\begin{aligned} \mathfrak{S}(\omega_+^+) &= \mathfrak{S}(\omega_-^-), \\ \mathfrak{S}(\omega_-^-) &= \mathfrak{S}(\omega_+^+). \end{aligned} \tag{4}$$

Remember that $(\omega_+^+)_0 = A_0$ and $(\omega_-^-)_0 = B_0$, so one gets that these four itineraries are determined by ω_+^+ and ω_-^- . If X exhibits a homoclinic loop, the equalities in equation (4) are no longer true. For instance, this is the case when $W_+^u(\sigma) \cap W_+^s(\sigma) \neq \emptyset$ and $W_-^u(\sigma) \cap W_-^s(\sigma) = \emptyset$, ω_+^+ is periodic, and ω_-^- is not. See Figure 25. However, since $\lim_{x \rightarrow c_-^-} f_X(x) = \lim_{x \rightarrow c_+^+} f_X(x)$ and $\lim_{x \rightarrow c_+^+} f_X(x) = \lim_{x \rightarrow c_-^-} f_X(x)$, the set \mathcal{A}_X is still determined by $\{\omega_+^+, \omega_-^-\}$ or $\{\omega_-^-, \omega_+^+\}$.

Itineraries of $\mathcal{H}_-^1 \cap \mathcal{H}_-^2$

$$\begin{aligned} \omega_+^+ &= A_0 B_0 A_0 B_0 \dots \\ \omega_-^- &= A_1 A_1 A_1 A_1 \dots \\ \omega_+^+ &= B_0 A_0 B_0 A_0 \dots \\ \omega_-^- &= B_0 B_0 B_0 B_0 \dots \end{aligned}$$

Itineraries of $\mathcal{H}_-^1 \cap \mathcal{H}_+^2$

$$\begin{aligned} \omega_+^+ &= A_0 B_0 B_0 B_0 \dots \\ \omega_-^- &= A_1 A_1 A_1 A_1 \dots \\ \omega_+^+ &= B_1 A_1 A_1 A_1 \dots \\ \omega_-^- &= B_0 B_0 B_0 B_0 \dots \end{aligned}$$

LEMMA 9.8. *If $p \in \Sigma$, then $\omega_-(p)$ and $\omega_+(p)$ are X -admissible.*

Proof. Consider an unstable segment $S: [0, 1] \rightarrow \Sigma$ whose interior is disjoint from γ_+^s and so that $S(0), S(1) \in \gamma_+^s$ and $p \in S([0, 1])$. Then Proposition 9.6 applies and implies that if $p \notin \gamma_+^s$, then $\omega_+^+ \preceq \omega_-(p) \preceq \omega_+(p) \preceq \omega_-^-$. In particular,

$$\begin{aligned} \omega_-^- &= \max\{\omega_-(p), \omega_+(p), p \in \Sigma\}, \\ \omega_+^+ &= \min\{\omega_-(p), \omega_+(p), p \in \Sigma\}. \end{aligned}$$

In particular, this shows that $\omega_-(p)$ and $\omega_+(p)$ satisfy the first item of the definition of X -admissibility.

The other two items correspond to several cases whose proof is very similar. Let us present one of these cases. Let $p = S(t)$ so that $(\omega_+(p))_0 \in \{A_0, A_1\}$. Then there is a decreasing sequence $t_n \rightarrow t$ so that $S(t_i) \notin W^s(\sigma)$ and $[\omega_+(p)]_n = [\omega^n]_n$, where ω^n denotes $\omega_-(S(t_n)) = \omega_+(S(t_n))$.

Then $\omega_+(p) = \inf \omega^n$. However, $S(t_n)$ is a point out of $W^s(\sigma)$ and contained in $A_0 \cup A_1$, and thus in Σ_1 . Proposition 9.6 implies that $\omega^n < \omega_-$, finishing this case and the proof. □

9.4. *Realizing X-admissible itineraries.* This section aims to prove the following proposition.

PROPOSITION 9.9. *Given any $\omega \in \mathcal{A}_X$, there is $p \in \Sigma$ so that*

$$\omega \in \{\omega_+(p), \omega_-(p)\}.$$

Remark 9.10. Proposition 9.6 implies that any two points satisfying the conclusion of Proposition 9.9 belong to the same stable leaf.

Proposition 9.9 is a direct consequence of Lemma 9.11.

LEMMA 9.11. *Given any $\omega \in \mathcal{A}_X$, the set Ω_n of points p in Σ so that*

$$[\omega]_n \in \{[\omega_+(p)]_n, [\omega_-(p)]_n\} \text{ is a non-empty compact subset of } \Sigma.$$

Assuming that Lemma 9.11 is true, then the sequence Ω_n is a nested sequence of non-empty compact sets, and any $p \in \bigcap \Omega_n$ satisfies that $\omega \in \{\omega_+(p), \omega_-(p)\}$. Note that, indeed, this intersection is precisely the stable leaf through p , according to Proposition 9.6. It remains to prove Lemma 9.11.

9.5. *Proof of Lemma 9.11.* For any itinerary $\omega \in \mathcal{A}_X$, we denote by $\Omega_n(\omega)$ the set of points $q \in \Sigma$ so that $[\omega]_n \in \{[\omega_-(q)]_n, [\omega_+(q)]_n\}$.

LEMMA 9.12. *Let $\omega \in \mathcal{A}_X$ so that there is some $p \in \Sigma$ for which $\omega \in \{\omega_-(p), \omega_+(p)\}$. Fix $n \in \mathbb{N}$ and denote $\Omega_n(\omega)$ the set of points $q \in \Sigma$ so that $[\omega]_n \in \{[\omega_-(q)]_n, [\omega_+(q)]_n\}$. Then $\Omega_n(\omega)$ is the closure of a connected component of*

$$\Gamma_n \stackrel{\text{def}}{=} \Sigma \setminus \bigcup_{i=0}^{n-1} P^{-i}(\gamma_+^s \cup P^{-1}(\gamma_+^s) \cup \gamma_-^s).$$

Proof. First, notice that Γ_n consists of the union of finitely many stable leaves. Consider an unstable segment $S: [0, 1] \rightarrow \Sigma$ whose interior is disjoint from Γ_n and has its endpoints on Γ_n . Let Ω_n be the closure of the connected component of $\Sigma \setminus \Gamma_n$ containing $S((0, 1))$. Then for any $0 \leq i < n$, $P^i(S((0, 1)))$ is well defined and disjoint from γ_\pm^s and of $P^{-1}(\gamma_+^s)$. In other words, $P^i(S((0, 1)))$ is contained in one of the regions representing the alphabet. Thus, $[\omega_-(S(t))]_n$ does not depend on $t \in (0, 1)$ and is equal to $[\omega_+(S(0))]_n$ and $[\omega_-(S(1))]_n$. One deduces that $[\omega_-]_n$ and $[\omega_+]_n$ are equal and constant on the interior of Ω_n , and $[\omega_-]_n$ takes the same value on one of the boundary stable leaves and $[\omega_+]_n$ on the other boundary stable leaf. This proves that $\Omega_n(\omega)$ is a union of such closures of connected components Ω_n .

Fix $\Omega_n \subset \Omega_n(\omega)$ and let $q \notin \Omega_n$. If q is not in the same region $\{A_0, A_1, B_0, B_1\}$ as Ω_n , then $[\omega_\pm(q)]_n$ is not $[\omega]_n$. Otherwise, there is an unstable segment (still denoted by S) in this region (hence disjoint from $\gamma_+^s \cup \gamma_-^s \cup P^{-1}(\gamma_+^s)$) joining q to a point p in the interior of Ω_n .

The interior $\text{int}(S)$ of segment S crosses the boundary of Ω_n that is crossed Γ_n . Let i be the smallest integer so that $\text{int}(S) \cap P^{-i}(\gamma_+^s \cup \gamma_-^s \cup P^{-1}(\gamma_+^s))$.

Then $P^{i-1}(S)$ is contained in the closure of one of the regions $\{A_0, A_1, B_0, B_1\}$ but not $P^i(S)$. This implies that the two endpoints of $P_i(S)$ are not in the same region $\{A_0, A_1, B_0, B_1\}$. This implies that $[\omega_+(q)]_i$ and $[\omega_-(q)]_i$ are different from $[\omega]_i$, proving that $q \notin \Omega_n(\omega)$ and finishing the proof. \square

Proof of Lemma 9.11. The proof goes by induction. We want to prove that for every $n \geq 0$ and every $\omega \in \mathcal{A}_X$, $\Omega_n(\omega)$ is the closure of one connected component of $\Sigma \setminus \Gamma_n$. Let us check if this is true for $n = 0$. Each itinerary of length 0 is one letter of our alphabet, which corresponds to a connected component of $\Sigma \setminus \Gamma_0$, and its closure is the one we announced. We now prove it also holds for $n = 1$. Assume, for instance, that $(\omega)_0 = A_0$. Thus, $\Omega_0(\omega) = \bar{A}_0$ and $P(\Omega_0(\omega))$ is a cuspidal triangle starting at q_1 and ending at γ_+^s . By definition of \mathcal{A}_X , one has $\omega_+(\gamma_+^s) \preceq \omega \preceq \omega_-(\gamma_-^s)$. As the first letter of ω is the same as the first letter of $\omega_+(\gamma_+^s)$, one gets $\omega_+(\gamma_+^s) = \omega_+(q_1) \preceq \mathfrak{S}(\omega)$. In particular, $(\omega)_1 = (\mathfrak{S}(\omega))_0$ either is strictly bigger than or is equal to $(\omega_+(q_1))_0$. In both cases, $P(\Omega_0(\omega))$ intersects $\Omega_0(\mathfrak{S}(\omega))$, proving that $\Omega_2(\omega)$ is not empty. Now Lemma 9.12 asserts that it is the closure of a connecting component of $\Sigma \setminus \Gamma_2$ proving the induction hypothesis in that case. The case $(\omega)_0 = A_1, B_0, B_1$ is very similar.

We assume that the induction hypotheses have been proved for $i = 0 \dots n$. Consider $\omega \in \mathcal{A}_X$. The induction hypothesis, $\Omega_n(\omega)$, is the closure of one connected component of $\Sigma \setminus \Gamma_n$. We split the proof into cases.

Case 1: γ_+^s and γ_-^s are not contained in the compact set $\Omega_n(\omega)$.

Then P is defined on $\Omega_n(\omega)$, and the boundary $\partial P(\Omega_n(\omega))$ is contained in Γ_{n-1} . This implies that $P(\Omega_n(\omega))$ crosses every stable leaf in the closure of a connected component of $\Sigma \setminus \Gamma_{n-1}$, which has to be $\Omega_{n-1}(\mathfrak{S}(\omega))$ (by Lemma 9.12). By the induction hypothesis, $\Omega_n(\mathfrak{S}(\omega))$ is a connected component of $\Sigma \setminus \Gamma_n$ and is contained in $\Omega_{n-1}(\mathfrak{S}(\omega))$. This implies that $P(\Omega_n(\omega))$ intersects $\Omega_{n-1}(\mathfrak{S}(\omega))$. Thus, $\Omega_{n+1}(\omega)$ is not empty and therefore is a connected component of $\Sigma \setminus \Gamma_{n+1}$ by Lemma 9.12.

Case 2: We now assume that one of the boundary components of $\Omega_n(\omega)$ is γ_+^s and the other is not γ_-^s . Up to reverse the orientation, we assume that the positively oriented unstable segments starting at γ_+^s enter in $\Omega_n(\omega)$. Then $P(\Omega_n(\omega))$ is a cuspidal triangle starting at q_1 and ending on a stable leaf in Γ_{n-1} . Now $\Omega_{n-1}(\mathfrak{S}(\omega))$ is (induction hypothesis) the closure of a connected component in $\Sigma \setminus \Gamma_{n-1}$, which contains $P(\Omega_n(\omega))$ and thus contains q_1 . Now $\Omega_n(\mathfrak{S}(\omega))$ is (induction hypothesis) the closure of a connected component in $\Sigma \setminus \Gamma_n$.

CLAIM 4. $P(\Omega_n(\omega)) \cap \Omega_n(\mathfrak{S}(\omega)) \neq \emptyset$.

Proof. Note that the first letter of ω is A_0 . As $\omega \in \mathcal{A}_X$, one has $\omega_+(\gamma_+^s) \preceq \omega$. As their first letters are equal, this implies $\omega_+(\gamma_+^s) = \omega_+(q_1) \preceq \mathfrak{S}(\omega)$. Consider a positively oriented unstable segment $S: [0, 1] \rightarrow \Sigma$ crossing every stable leaf in $\Omega_{n-1}(\mathfrak{S}(\omega))$ and containing $q_1 = S(t_0)$. Then S is crossing $\Omega_n(\mathfrak{S}(\omega))$ at point $S(t)$. Recall that $\omega_+(q_1) \preceq \mathfrak{S}(\omega)$. Recall that the function $[\omega_+(S(t))]_n$ is non-decreasing with t , so that $S^{-1}(\Omega_n(\mathfrak{S}(\omega))) \subset [0, 1]$ is not inferior to $S^{-1}(\Omega_n(\omega_+(q_1)))$. As a consequence, $S^{-1}(\Omega_n(\mathfrak{S}(\omega))) \subset [0, 1]$ either

coincides with $S^{-1}(\Omega_n(\omega_+(q_1)))$ or is strictly larger than t_0 . In both cases, $P(\Omega_n(\omega))$ intersects $\Omega_n(\mathfrak{S}(\omega))$, concluding the proof of the claim. \square

This implies that $\Omega_{n+1}(\omega)$ is not empty, and Lemma 9.12 concludes that case.

Case 3: We now assume that one of the boundary components of $\Omega_n(\omega)$ is γ_-^s and the other is not γ_+^s .

Up to reverse the orientation, we assume that the positively oriented unstable segments starting at γ_+^s enter in $\Omega_n(\omega)$. Then $P(\Omega_n(\omega))$ is a cuspidal triangle starting at q_2 and ending on a stable leaf in Γ_{n-1} . Note that the first letter of ω is B_0 . As $\omega \in \mathcal{A}_X$, one has $\omega_+(\gamma_-^s) \preceq \omega$. As their first letters are equal, this implies

$$\mathfrak{S}(\omega) \preceq \mathfrak{S}\omega_+(\gamma_+^s) = \omega_+(q_2).$$

The proof follows now in a similar way to Case 2.

Case 4: Finally, we assume that both boundary components of $\Omega_n(\omega)$ are γ_-^s and γ_+^s . This implies that $\Omega_n(\omega)$ is the closure of Σ_1 or of Σ_2 , and thus $P(\Sigma)$ crosses $\Omega_n(\mathfrak{S}(\omega))$ concluding. Now the proof of Lemma 9.11 (and therefore of Proposition 9.9) is complete. \square

9.6. Itineraries, conjugacy, and topological equivalence

THEOREM 9.13. *Consider $X, Y \in \mathcal{O}_1$ and let f_X, f_Y be the corresponding one-dimensional dynamics. Assume that the itineraries $\omega_-(\gamma_-^s, X) = \omega_-(\gamma_-^s, Y)$ and $\omega_-(\gamma_+^s, X) = \omega_-(\gamma_+^s, Y)$. Then there is an orientation-preserving map of \mathbb{S}^1 , which is a conjugation between f_X and f_Y .*

Proof. We have seen that the sets \mathcal{A}_X and \mathcal{A}_Y of admissible itineraries for X and Y are wholly determined by $\omega_-(\gamma_\pm^s, X)$ and $\omega_-(\gamma_\pm^s, Y)$, respectively. Thus, $\mathcal{A}_X = \mathcal{A}_Y \stackrel{\text{def}}{=} \mathcal{A}$.

Now for any $\omega \in \mathcal{A}$, Proposition 9.11 and Remark 9.10 imply that there is a unique point $x_\omega \in \mathbb{S}_X^1$ and $y_\omega \in \mathbb{S}_Y^1$ so that $\omega \in \{\omega_-(x_\omega, f_X), \omega_+(x_\omega, f_X)\}$ and $\omega \in \{\omega_-(y_\omega, f_Y), \omega_+(y_\omega, f_Y)\}$.

We define $h(x_\omega) = y_\omega$. This defines a bijection from \mathbb{S}_X^1 to \mathbb{S}_Y^1 , which sends $\gamma_{i,X}^s$ on $\gamma_{i,Y}^s$. The punctured circle is an interval endowed with an order (from the positive orientation of the unstable segments), and Proposition 9.6 implies that $\omega \mapsto x_\omega$ and $\omega \mapsto y_\omega$ are increasing. This implies that $h: x_\omega \mapsto y_\omega$ is an increasing bijection from $\mathbb{S}_X^1 \setminus \{\gamma_{+,X}^s\}$ onto $\mathbb{S}_Y^1 \setminus \{\gamma_{+,Y}^s\}$. An increasing bijection between intervals is a homeomorphism and so h is a homeomorphism. The fact that h is a conjugacy now comes from the fact that $x_{\mathfrak{S}(\omega)} = f_X(x)$ for $x \notin \{\gamma_\pm^s, X\}$. \square

Recall that the discontinuities are fixed points for the conjugacy h constructed above. We finish proving Theorem H, which establishes that the restriction to the maximal invariant set of $X, Y \in \mathcal{O}_1$ is topologically equivalent by a conjugacy close to identity if, and only if, X and Y have the same itineraries.

We are ready to present a proof of Theorem H.

Proof. (of Theorem H). (\Rightarrow) A conjugation \mathbb{H} between $X|_{\Lambda_X}$ and $Y|_{\Lambda_Y}$ induces a topological conjugation $h : \mathbb{S}^1 \rightarrow \mathbb{S}^1$ between $f_X : \mathbb{S}^1 \rightarrow \mathbb{S}^1$ and $f_Y : \mathbb{S}^1 \rightarrow \mathbb{S}^1$. Let $\varepsilon = \frac{1}{2} \min\{d(D_1, \Sigma; d(D_2, \Sigma))\}$ (see §3.1 for the definitions of D_1 and D_2). If $d(\mathbb{H}, id) < \varepsilon$, h is orientation preserving and $h(c_{i,X}) = c_{i,Y}$ for $i \in \{-, +\}$, and therefore X and Y have the identical itineraries.

(\Leftarrow) Fix $p \in \Sigma \cap \Lambda_X$. Because X and Y have the same itineraries, Lemma 9.11 together with Theorem 9.13 ensures the existence of $q \in \Sigma \cap \Lambda_Y$ such that for all $n \in \mathbb{N}$, points in $\gamma_X^s(P_X^{-n}(p))$ and $\gamma_Y^s(P_Y^{-n}(q))$ have the same itineraries. Thus, $C_n = \{P_Y^n(\gamma_Y^s(P_Y^{-n}(q)))\}_{n \in \mathbb{N}}$ is a sequence of compact sets in $\gamma_Y^s(q)$ converging to a single point, and we define $H(p) = \bigcap_{n \in \mathbb{N}} C_n$. Lemma 9.8 implies that H is onto. For $p_1, p_2 \in \Sigma$ such that $\gamma_X^s(p_1) \neq \gamma_X^s(p_2)$, it is easy to see that $H(p_1) \neq H(p_2)$. For p_1 and p_2 in the same leaf, there exists $n_1 \in \mathbb{N}$ for which $P^{-n_1}(p_1)$ and $P^{-n_1}(p_2)$ belongs to different connected component of $\Sigma \setminus \{\gamma_{-,X}^s, \gamma_{+,X}^s\}$, which implies that $\gamma_X^s(P_X^{-n_1}(p_1)) \cap \gamma_X^s(P_X^{-n_1}(p_2)) = \emptyset$ and hence $H_n(p_1) \cap H_n(p_2) \neq \emptyset$ for all $n > n_1$, providing H injectivity. The existence of unstable cone fields around Σ and the continuity of h and h^{-1} give the continuity of H and H^{-1} . To finish, for $p \in \Sigma \cap \Lambda_X$, consider $\alpha \subset \mathcal{O}(p)$ and $\beta \subset \mathcal{O}(H(p))$, curves parameterized by the arc length, joining p to $D^1 \cup D^2$ and $H(p)$ to $D^1 \cup D^2$, respectively, in a way that $\alpha(t_1), \beta(t_2) \notin D^1 \cup D^2$ for all $0 < t_1 < \ell(\alpha)$ and $0 < t_2 < \ell(\beta)$. For ρ being the ratio of the length of α to the length of β , we define $\mathbb{H}(t) = \beta(\rho t)$. Extend this map to segments of trajectories leaving $D^1 \cup D^2$ and returning to Σ in the same way as before. Here, \mathbb{H} defines a topological equivalence. Note that $\mathbb{H}(D_i) = D_i$ and $\mathbb{H}(\Sigma) = \Sigma$, which implies that $d(\mathbb{H}, id) < \varepsilon$ and we have the result. \square

Acknowledgements. The authors extend their gratitude to the referee for the valuable comments which improved the final version of the manuscript. D.B. and M.J.P. were partially supported by CAPES-Finance Code 001. C.B. and M.J.P. were partially supported by the Brazilian-French Network in Mathematics, and M.J.P. was partially supported by CNPq-Brazil Grant No. 302565/2017-5, FAPERJ (CNE) Grant-Brazil No. E-26/202.850/2018(239069), Pronex: E-26/010.001252/2016.

REFERENCES

- [1] V. S. Afraimovich, V. V. Bykov and L. P. Shil'nikov. On the origin and structure of the Lorenz attractor. *Akad. Nauk SSSR Doklady* **234** (1977), 336–339.
- [2] V. S. Afraimovich, V. V. Bykov and L. P. Shil'nikov. On attracting structurally unstable limit sets of Lorenz attractor type. *Tr. Moskov. Mat. Obshch.* **44** (1982), 150–212 (in Russian).
- [3] V. S. Afraimovich and Y. Pesin. The dimension of Lorenz type attractors. *Sov. Math. Phys. Rev.* **6** (1983), 169–241.
- [4] V. Araújo. On the statistical stability of families of attracting sets and the contracting Lorenz attractor. *J. Stat. Phys.* **182** (2021), 53.
- [5] V. Araújo, S. Galatolo and M. J. Pacifico. Statistical properties of Lorenz-like flows, recent developments and perspectives. *Internat. J. Bifur. Chaos Appl. Sci. Engrg.* **24** (2014), 1430028.
- [6] V. Araújo and I. Melbourne. Exponential decay of correlations for nonuniformly hyperbolic flows with a $C^{1+\alpha}$ stable foliation, including the classical Lorenz attractor. *Ann. Henri Poincaré* **17** (2016), 2975–3004.
- [7] V. Araújo and I. Melbourne. Existence and smoothness of the stable foliation for sectional hyperbolic attractors. *Bull. Lond. Math. Soc.* **49** (2017), 351–367.
- [8] V. Araújo, I. Melbourne and P. Varandas. Rapid mixing for the Lorenz attractor and statistical limit laws for their time-1 maps. *Comm. Math. Phys.* **340** (2015), 901–938.

- [9] V. Araújo and M. J. Pacifico. *Three-Dimensional Flows (Ergebnisse der Mathematik und ihrer Grenzgebiete. 3. Folge / A Series of Modern Surveys in Mathematics, 53)*. Springer Science & Business Media, Berlin, 2010.
- [10] V. Araújo and M. J. Pacifico. Lorenz-like chaotic attractors revised. *Dynamics, Games and Science I (Springer Proceedings in Mathematics, 1)*. Ed. M. M. Peixoto, A. A. Pinto and D. A. Rand. Springer, Heidelberg, 2011, pp. 61–79.
- [11] V. Araújo, M. J. Pacifico, P. Pujals and M. Viana. Singular-hyperbolic attractors are chaotic. *Trans. Amer. Math. Soc.* **361** (2009), 2431–2485.
- [12] V. Araújo and P. Varandas. Robust exponential decay of correlations for singular-flows. *Comm. Math. Phys.* **311** (2012), 215–246.
- [13] L. Bumimovich and Y. Sinai. Stochasticity of the attractor in the Lorenz model. *Nonlinear Waves (Proceeding of Winter School, Gorki, 1977)*. Ed. A. V. Gaponov-Grekhov. Nauka, Moscow, 1979, pp. 212–226.
- [14] C. Conley. Some aspects of the qualitative theory of differential equations. *Dynamical Systems (Proceedings of the International Symposium, Brown University, Providence, RI, 1974)*. Ed. L. Cesari, J. K. Hale and J. P. Lasalle. Vol. I. Academic Press, New York, 1976, pp. 1012.
- [15] L. Díaz. Robust nonhyperbolic dynamics and heterodimensional cycles. *Ergod. Th. & Dynam. Sys.* **15** (1995), 291–315.
- [16] S. Galatolo and I. Nisoli. Rigorous computation of invariant measures and fractal dimension for maps with contracting fibers: 2D Lorenz-like maps. *Ergod. Th. & Dynam. Sys.* **36**(6) (2016), 1865–1891.
- [17] S. Galatolo, I. Nisoli and M. J. Pacifico. Decay of correlations, quantitative recurrence and logarithm law for contracting Lorenz attractors. *J. Stat. Phys.* **170**(5) (2018), 862–882.
- [18] S. Galatolo and M. J. Pacifico. Lorenz-like flows: exponential decay of correlations for the Poincaré map, logarithm law, quantitative recurrence. *Ergod. Th. & Dynam. Sys.* **30** (2010), 1703–1737.
- [19] S. Gonchenko, E. Karatetskaia, A. Kazakov and V. Kruglov. Conjoined Lorenz twins—a new pseudohyperbolic attractor in three-dimensional maps and flows. *Chaos* **32**(12) (2022), Paper no. 121107, 13pp.
- [20] S. V. Gonchenko, L. P. Shilnikov and D. Turaev. On global bifurcations in three-dimensional diffeomorphisms leading to wild Lorenz-like attractors. *Regul. Chaotic Dyn.* **14**(1) (2009), 137–147.
- [21] J. Guckenheimer. A strange, strange attractor. *The Hopf Bifurcation and Its Applications*. Ed. J. E. Marsden and M. McCracken. Springer, New York, 1976, pp. 368–381.
- [22] J. Guckenheimer and P. Holmes. *Nonlinear Oscillations, Dynamical Systems, and Bifurcations of Vector Fields (Applied Mathematical Sciences, 42)*. Springer, New York, 1983.
- [23] J. Guckenheimer and R. F. Williams. Structural stability of Lorenz attractors. *Publ. Math. Inst. Hautes Études Sci.* **50** (1979), 59–72.
- [24] P. Hartman. *Ordinary Differential Equations (Classics in Applied Mathematics, 38)*. Society for Industrial and Applied Mathematics (SIAM), Philadelphia, PA, 2002; corrected reprint of the second (1982) edition.
- [25] B. Hassard, S. Hastings, W. Troy and J. Zhang. A computer proof that the Lorenz equations have “chaotic” solutions. *Appl. Math. Lett.* **7** (1994), 79–83.
- [26] S. Hastings and W. Troy. A shooting approach to the Lorenz equations. *Bull. Amer. Math. Soc.* **27** (1992), 298–303.
- [27] M. W. Hirsch, C. C. Pugh and M. Shub. *Invariant Manifolds (Lecture Notes in Mathematics, 583)*. Springer-Verlag, Berlin, 1977.
- [28] A. Kazakov. On bifurcations of Lorenz attractors in the Lyubimov–Zaks model. *Chaos* **31**(9) (2021), 093118.
- [29] D. Li and D. Turaev. Persistent heterodimensional cycles in periodic perturbations of Lorenz-like attractors. *Nonlinearity* **33** (2020), 971–1015.
- [30] E. N. Lorenz. Deterministic nonperiodic flow. *J. Atmos. Sci.* **20** (1963), 130–141.
- [31] S. Luzzatto, I. Melbourne and F. Paccaut. The Lorenz attractor is mixing. *Comm. Math. Phys.* **260** (2005), 393–401.
- [32] D. V. Lyubimov and M. A. Zaks. Two mechanisms of the transition to chaos in finite-dimensional models of convection. *Phys. D* **9**(1–2) (1983), 52–64.
- [33] R. Mañé. A proof of the C^1 stability conjecture. *Publ. Math. Inst. Hautes Etudes Sci.* **66** (1987), 161–210.
- [34] K. Mischaikow and M. Mrozek. Chaos in the Lorenz equations: a computer assisted proof (I). *Bull. Amer. Math. Soc. (N.S.)* **32** (1995), 66–72.
- [35] K. Mischaikow and M. Mrozek. Chaos in the Lorenz equations: a computer assisted proof (II). *Math. Comp.* **67** (1998), 1023–1046.
- [36] L. Mora and C. Lizana. Lower bounds for the Hausdorff dimension of the geometric Lorenz attractor the homoclinic case. *Discrete Contin. Dyn. Syst.* **22**(3) (2008), 699–709.
- [37] C. A. Morales, M. J. Pacifico and E. Pujals. Robust transitive singular sets for 3-flows are partially hyperbolic attractors or repellers. *Ann. of Math. (2)* **160** (2004), 375–432.

- [38] C. A. Morales, M. J. Pacifico and B. San Martín. Expanding Lorenz attractors through resonant double homoclinic loops. *SIAM J. Math. Anal.* **36**(6) (2005), 1836–1861.
- [39] C. A. Morales, M. J. Pacifico and B. San Martín. Contracting Lorenz attractors through resonant double homoclinic loops. *SIAM J. Math. Anal.* **38**(1) (2006), 309–332.
- [40] C. G. Moreira, M. J. Pacifico and S. Romaña Ibarra. Hausdorff dimension, Lagrange and Markov dynamical spectra for geometric Lorenz attractors. *Bull. Amer. Math. Soc. (N.S.)* **57** (2020), 269–292.
- [41] I. I. Ovsyannikov and D. Turaev. Analytic proof of the existence of the Lorenz attractor in the extended Lorenz model. *Nonlinearity* **30** (2017), 115–137.
- [42] M. J. Pacifico. Structural stability of vector fields on 3-manifolds with boundary. *J. Differential Equations* **54**(3) (1984), 346–372.
- [43] M. J. Pacifico and M. Todd. Thermodynamic formalism for contracting Lorenz flows. *J. Stat. Phys.* **139**(1) (2010), 159–176.
- [44] M. J. Pacifico, F. Yang and J. Yang. Equilibrium states for the classical Lorenz attractor and sectional-hyperbolic attractors in higher dimensions. *Preprint*, 2023, [arXiv:2209.10784](https://arxiv.org/abs/2209.10784).
- [45] C. Robinson. Transitivity and invariant measures for the geometric model of the Lorenz equations. *Ergod. Th. & Dynam. Sys.* **4** (1984), 605–611.
- [46] C. Robinson. Homoclinic bifurcation to a transitive attractor of Lorenz type. *Nonlinearity* **2** (1989), 495–518.
- [47] C. Robinson. Homoclinic bifurcation to a transitive attractor of Lorenz type. II. *SIAM J. Math. Anal.* **23** (1992), 1255–1268.
- [48] C. Robinson. Nonsymmetric Lorenz attractors from a homoclinic bifurcation. *SIAM J. Math. Anal.* **32** (2000), 119–141.
- [49] M. R. Rychlik. Lorenz attractors through Shilnikov-type bifurcation. *Ergod. Th. & Dynam. Sys.* **10** (1990), 793–821.
- [50] L. P. Shilnikov. Bifurcation theory and quasihyperbolic attractors. *Uspekhi Mat. Nauk* **36** (1981), 240–241.
- [51] Y. Sinai. Hyperbolic conditions for the Lorenz model. *Phys. D* **2** (1981), 3–7.
- [52] S. Smale. Differentiable dynamical systems. *Bull. Amer. Math. Soc. (N.S.)* **73** (1967), 747–817.
- [53] D. Smania and J. Vidarte. Existence of C^k -invariant foliations for Lorenz-type maps. *J. Dynam. Differential Equations* **30** (2018), 227–255.
- [54] C. Sparrow. *The Lorenz Equations: Bifurcations, Chaos and Strange Attractors*. Springer, New York, NY, 1982.
- [55] T. Steingenberg. Hausdorff dimension of attractor for two dimensional Lorenz transformations. *Israel J. Math.* **116** (2000), 253–269.
- [56] W. Tucker. The Lorenz attractor exists. *C. R. Acad. Sci. Ser. I Math.* **328** (1999), 1197–1202.
- [57] W. Tucker. A rigorous ODE solver and Smale’s 14th problem. *Found. Comput. Math.* **2**(1) (2002), 53–117.
- [58] M. Viana. What’s new on Lorenz strange attractors? *Math. Intelligencer* **22**(3) (2000), 6–19.
- [59] D. Viswanath. The fractal property of the Lorenz attractor. *Phys. D* **190** (2004), 115–128.
- [60] R. Williams. One-dimensional nonwandering sets. *Topology* **6** (1967), 473–487.
- [61] R. Williams. Expanding attractors. *Publ. Math. Inst. Hautes Études Sci.* **43** (1974), 169–203.
- [62] R. Williams. The structure of Lorenz attractors. *Publ. Math. Inst. Hautes Études Sci.* **50** (1979), 73–99.